

# Vertical and Horizontal Centrifugal Pumps Reliability – a Given with Lutz

Series:  
B50, B6  
B80 HME, B80 KME, B80 KGK  
TMB, AM, TMR



**Safety is our Concern**

# Lutz Centrifugal Pumps

The product range at a glance



## Lutz centrifugal pumps

Here, everything revolves around safety and environmental protection: Lutz centrifugal pumps ensure the safe delivery of aggressive, corrosive and other hazardous acids or alkalis.

### Well thought-out modular system

The individual component sizes, the technical constructions and materials of the vertical, wet-well immersion pump series can be combined as desired.

### Areas of application

Centrifugal pumps are especially suited for use in electroplating and sewage engineering, in the chemical industry, in the field of water treatment and in gas purifying systems.



## B50

**For neutral and aggressive fluids**

Delivery rate: up to 12 m<sup>3</sup>/h  
 Delivery head: up to 22 m  
 Materials: Polypropylen  
 Temperature of pumped medium: up to 50 °C  
 Immersion depths: up to 2.000 mm



## B6

**For neutral and aggressive fluids with a small amount of solid matter**

Delivery rate: up to 60 m<sup>3</sup>/h  
 Delivery head: up to 15 m  
 Materials: Polypropylene or stainless steel  
 Temperature of pumped medium: up to 100°C  
 Immersion depths: up to 3.000 mm



## B80

**For neutral and aggressive fluids with a large amount of solid matter**

Delivery rate: up to 270 m<sup>3</sup>/h  
 Delivery head: up to 85 m  
 Materials: Polypropylene, polyvinylidenfluoride or polyvinyl chloride  
 Temperature of pumped medium: up to 90°C  
 Immersion depths: up to 4.000 mm (with tail-pipe extension up to 2.000 mm)

**Tip**

Pumps in horizontal construction see page 32.



# Vertical Centrifugal Pumps



## Submersible Centrifugal Pump B50



### Safety is our maxim

For example, reliability, safety and not the least important functionality are called for during the recirculation of chemicals and pickling baths. This submersible centrifugal pump was developed especially as a vertical, wet pump for the fast emptying of vessels and basins. Lutz placed considerable value thereby on low wear, large pumping capacity and short emptying times. Its low weight makes this pump especially user-friendly.

- ✓ High efficiency
- ✓ High pumping capacity
- ✓ Smooth running
- ✓ Low space requirement
- ✓ Fast assembly
- ✓ Simple starting
- ✓ Easy maintenance

Product detail		Submersible centrifugal pump		B50 PP/HC	B50 PP/SS
	Category 1 / 2 (acc. to ATEX)			no	no
	Immersion tube diameter:	max. mm		100	100
	Temperature of medium:	max. °C		40	40
	Material:	Pump tube		PP	PP
		Impeller/diffuser material		PPO / PPE	PPO / PPE
		Drive shaft		Hastelloy C (2.4610)	Stainless steel (1.4571)
	Outrun piece:			G 1 1/2 Outer thread	G 1 1/2 Outer thread
Length: 1100 mm Special length on request	Order No.		<b>0180-000</b>	<b>0180-500</b>	
		<b>Choice of motors</b>	<b>Operating data</b>		
	<b>Single phase motor</b>				
	Output:	0.55 kW    0.75 kW	Delivery rate* up to l/min.	200	200
	Dichte:	up to 1.3 kg/dm <sup>3</sup> up to 1.8 kg/dm <sup>3</sup>	Delivery head* up to m wc	22	22
	Speed:	2800 1/min.    2700 1/min.	Viscosity up to mPas	100	100
	Prot. class:	IP 54    IP 54	Weight (kg) Motor + pump tube	10.5 – 13.5	10.5 – 13.5
	Order No.	<b>0180-030    0180-031</b>			

Single-phase motor with operating condenser (230 V, 50 Hz) with 5m connection cable and shock-proof plug.



# Submersible Centrifugal Pump B50

High pumping capacity and low space requirements

## Materials (coming into contact with the pumped medium)

Pump	B50 PP/HC	B50 PP/SS
Pump tube:	Polypropylene (PP)	Polypropylene (PP)
Stator:	PPO / PPE	PPO / PPE
Mechanical seal:	Carbon / SiC / HC	Carbon / SiC / HC
Secondary seal:	FPM (EPDM)	FPM (EPDM)
Drive shaft:	HC-4 (2.4610)	Stainless steel (1.4571)

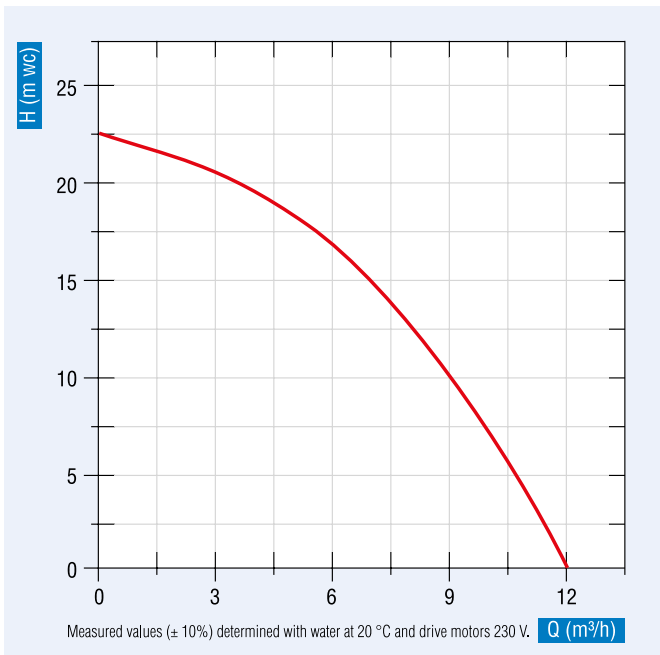

## Practical pumping capacity

The submersible pump built on the basis of the latest hydraulic knowledge and the proven single-tube principle can be used everywhere where vessels and basins must be emptied or filled quickly and safely.

The pump is equipped with self-lubricating, wetted friction bearings.

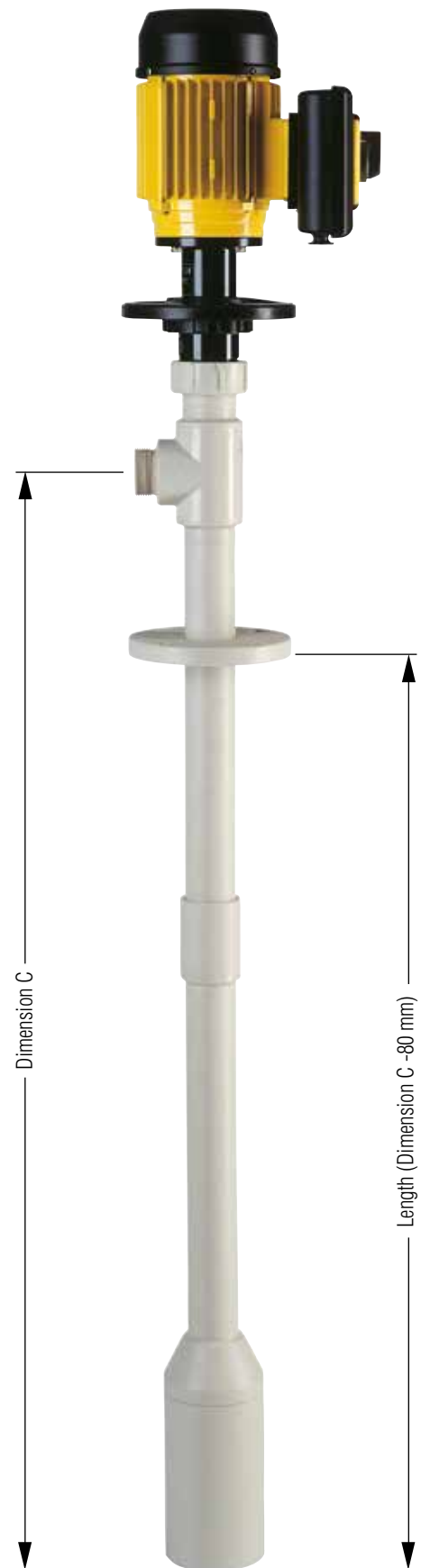

Suitable range of accessories  
see page 10.

# Lutz Vertical Centrifugal Pumps

Submersible Centrifugal Pump B6: The cost-effective solution for the plant construction industry

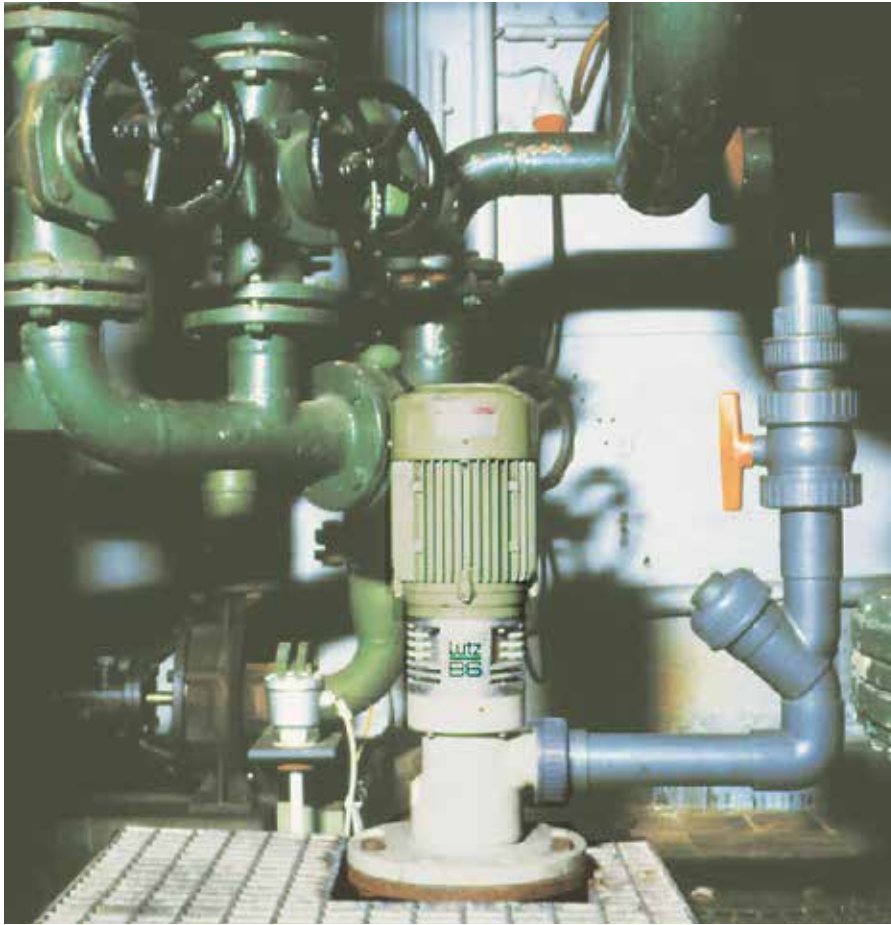

## If safety is your concern: Lutz B6 submersible centrifugal pump

Some liquids are not only hazardous but must, on account of the building situation, be pumped through holes above the liquid level. Pipe ends in the side or the bottom of the container are not permissible for such media. Lutz B6 submersible centrifugal pumps made from PP or stainless steel solve this problem in an elegant way “from the top” – don't worry, despite all these qualities they are absolutely straight-forward and undemanding in their handling.

- ✓ Highly cost-effective
- ✓ Small space requirement
- ✓ Many application options
- ✓ Easy installation
- ✓ Rapidly ready for use
- ✓ High temperature resistance and economic efficiency.

## Experience is the best protection

A development you can trust in: Lutz B6 submersible centrifugal pumps have been in use for many years. Construction and materials are optimally matched to aggressive liquids which are potentially harmful to the environment. The correct solution for many tasks in surface treatment, the chemical industry, the mineral oil industry and the coating and paint industry, in foundries and in water decontamination.

## “Let's get started”

Lutz will provide you – as always – with the correct pump tube for every medium. The PP pump tube is the correct solution for neutral and aggressive liquids. The stainless steel pump tube (1.4571) is also resistant to corrosion and therefore suitable for both neutral and aggressive liquids.

## All the accessories

Float controller, foot strainer, installation flange, outlet flange, hose connector, motor protection switch, also Ex-proof, connection cable, Cekon plug and Ex-plug.

# Submersible Centrifugal Pump B6

No matter whether you are using stainless steel or PP: it is the same construction principle everywhere

## Thought-through design: A great little pump

High performance, compact dimensions, low weight – everything fits with Lutz B6. The pump shaft is protected by an inner tube against any “attack” from the pumped medium. Small is best for the installed dimensions, and for this reason the liquid is pumped upwards between the inner and the outer tube.

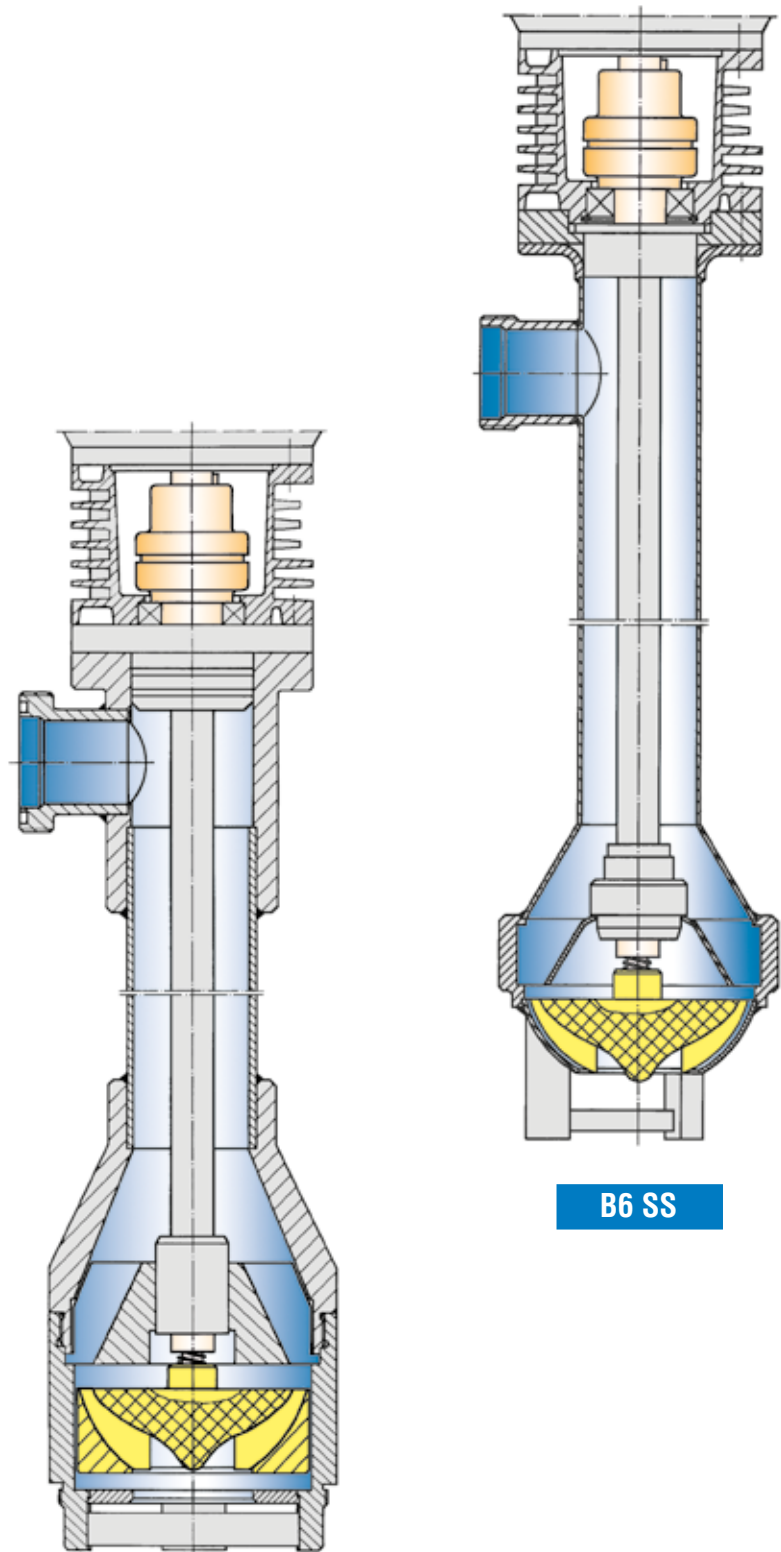



B6 SS

B6 PP

# Lutz Vertical Centrifugal Pumps

## Submersible Centrifugal Pump B6 in polypropylene (PP) and stainless steel (SS)

Product detail		Pump tube	B6/15 PP	B6/30 PP	B 6/45 PP	B6/60 PP
	Category 1 / 2 (acc. to ATEX)		no	no	no	no
	Shaft seal		MS	MS	MS	MS
	Delivery rate*	up to m³/h	24	33	42	56
	Delivery head*	up to m wc	9	11	12	15
	Viscosity**	up to mPas	4000	3000	2000	1200
	Temperature of medium	max. °C	50	50	50	50
	Materials	Pump tube	PP	PP	PP	PP
		Impeller	PP	PP	PP	PP
	Immersion tube diameter	max. mm	166	166	166	166
	Pressure joint	Outer thread	G 2 3/4	G 2 3/4	G 2 3/4	G 2 3/4
	Weight (Pump tube 1000 mm + motor)	kg	32	36	45	43
	Minimum necessary motor power for density 1 kg/dm³	[kW]	1.35	1.95	2.50	3.60
	Length 400-1000 mm (when ordering please quote)	Order No.	<b>0118-047</b>	<b>0118-049</b>	<b>0118-051</b>	<b>0118-053</b>
	Supplementary length 100 mm (possible from 1100 - 3000 mm)	Order No.	<b>0118-419</b>	<b>0118-419</b>	<b>0118-419</b>	<b>0118-419</b>

Pump tube		B6/15 SS	B6/30 SS	B 6/45 SS	B6/60 SS	
	Category 1 / 2 (acc. to ATEX)		no	no	no	
	Shaft seal		MS	MS	MS	
	Delivery rate*	up to m³/h	21	33	39	51
	Delivery head*	up to m wc	8	11	11,5	14
	Viscosity**	up to mPas	4000	3000	2000	1200
	Temperature of medium	max. °C	100	100	100	100
	Material	Pump tube	1.4571	1.4571	1.4571	1.4571
		Impeller	ETFE	ETFE	ETFE	ETFE
	Immersion tube diameter	max. mm	160	160	160	160
	Pressure joint	Outer thread	G 2 1/4	G 2 1/4	G 2 1/4	G 2 1/4
	Weight (Pump tube 1000 mm + motor)	ca. kg	35	39	48	46
	Minimum necessary motor power for density 1 kg/dm³	[kW]	1.05	1.75	1.80	3.30
	Length 400-1000 mm (when ordering please quote)	Order No.	<b>0118-067</b>	<b>0118-069</b>	<b>0118-071</b>	<b>0118-073</b>
	Supplementary length 100 mm (possible from 1100 - 3000 mm)	Order No.	<b>0118-421</b>	<b>0118-421</b>	<b>0118-421</b>	<b>0118-421</b>

\*determined with water at 20 °C \*\* determined with oil  
The immersion depths specified in the table are measured from lower surface of the pump foot to center discharge (dimension C in the dimensional drawing).  
When using an installation flange, the submersion depth is reduced.

### Choice of motors



Type	1.5 kW, IP 55	2.2 kW, IP 55	3.0 kW, IP 55	4.0 kW, IP 55	1.5 kW, IP 54 protection switch
Order No.	<b>0006-080</b>	<b>0006-082</b>	<b>0006-084</b>	<b>0006-085</b>	<b>0006-081</b>
Type	2.2 kW, IP 54 Protection switch	1.3 kW EEx e II T3, IP 54	1.85 kW EEx e II T3, IP 54	2.5 kW EEx e II T3, IP 54	3.3 kW EEx e II T3, IP 54
Order No.	<b>0006-083</b>	<b>0006-303</b>	<b>0006-304</b>	<b>0006-305</b>	<b>0006-306</b>

### Three phase motor

Output 1.5 up to 4.0 kW, 230/400 V, 50 Hz, approx. 2800 1/min., energy efficiency class IE 3 in accordance with EU regulations 640/2009 and 04/2014, protection class IP 54/IP 55.



# Submersible Centrifugal Pump B6

No experiments

## Materials (coming into contact with the pumped medium):

	B6 PP	B6 SS
Housing:	PP	Stainless Steel (1.4571)
Impeller:	PP	ETFE
Seals:	FPM	FPM
Mechanical Seal:	Ceramic, FPM, HC	Ceramic, FPM, SS
Drive shaft:	HC-4 (2.4610)	Stainless steel (1.4571)

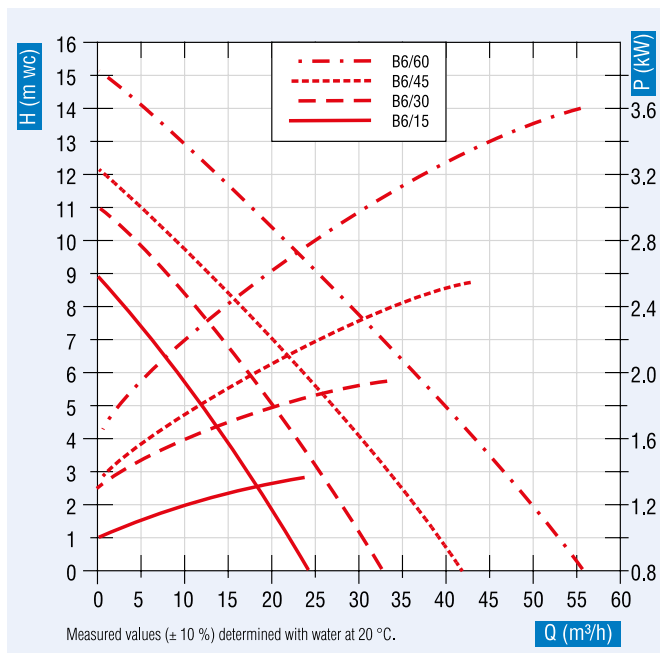

Dimension curve B6 PP

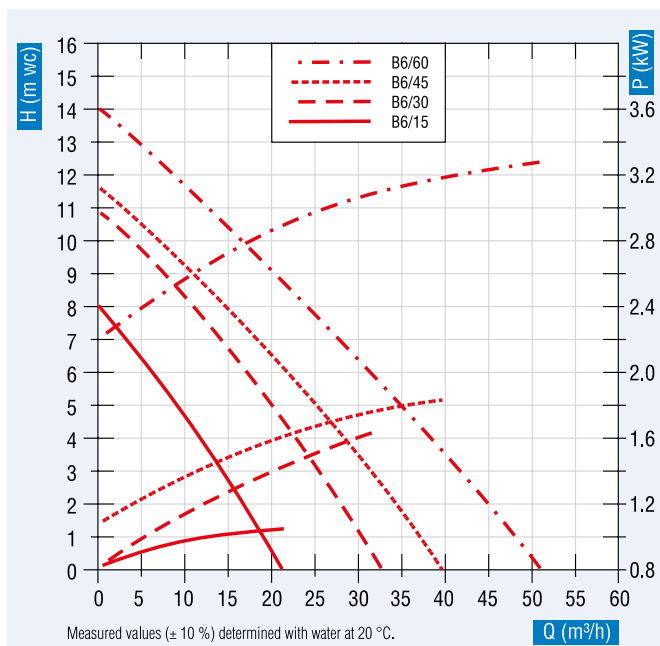

Dimension curve B6 SS



Suitable range of accessories see page 11-13.

# Accessories



## Submersible Centrifugal Pump B50

Product detail	Specification	Order-No.
	<p><b>Lifting device</b> To simplify the process of lifting the pump in and out of tanks or containers.</p>	<p><b>0155-154</b></p>
	<p><b>Hose connection</b> Hose plug with wing nut for connecting the hose to the pump tube or nozzle.</p> <p>Material: PP Nominal diameter: DN 38</p>	<p><b>0180-161</b></p>
	<p><b>Installation flange</b> For fixing the drum pump to a companion flange. The flange is welded onto the pump tube. Other flange dimensions on request.</p> <p>DN 100, PN 10 DIN 2576</p>	<p><b>0180-175</b></p>
	<p><b>Discharge flange</b> Complete with seal.</p> <p>DN 40, PN 6 DIN 2566</p>	<p><b>0180-178</b></p>
	<p><b>Reducing sleeve</b> G 1 1/2 inner thread to G 1 1/4 outer thread for connecting a flow meter</p> <p><b>Reducing sleeve</b> G 1 1/2 outer thread to G 1 1/4 inner thread for hose diameter ND 38 when using a flow meter</p>	<p><b>0180-167</b></p> <p><b>0180-169</b></p>
	<p><b>Foot strainers</b> Keeps impurities away from the rotating parts.</p> <p>Material: PP</p>	<p><b>0180-174</b></p>
	<p><b>Acid proof coating</b> In aggressive atmosphere the three phase motor should be protected by a special acid proof coating. If customer requires, a special varnish is possible.</p> <p>Acid proof coating</p>	<p><b>0006-516</b></p>





Specification	Order-No.	Product detail															
<p><b>Hose connection</b> Hose connection with wing nut and seal for connecting the hoses to the the pump tube.</p> <p><b>For B6/PP</b> Wing nut PP G 2 3/4 O-ring PP Hose plug PP DN 25 Hose plug PP DN 32 Hose plug PP DN 38 Hose plug PP DN 50 Hose plug PP DN 63</p> <p><b>For B6/Niro</b> Wing nut stainless steel G 2 1/4 Seal PTFE Hose plug stainless steel DN 25 Hose plug stainless steel DN 32 Hose plug stainless steel DN 38 Hose plug stainless steel DN 50</p>	<p><b>0303-200</b> <b>0118-380</b> <b>0118-157</b> <b>0118-158</b> <b>0118-159</b> <b>0118-160</b> <b>0118-161</b></p>																
<p><b>Installation flange</b> For fixing the drum pump to a companion flange. The flange is welded onto the pump tube.</p> <p><b>For B6/PP</b> DN 150, PN 6           DIN 2573 DN 150, PN 10        DIN 2576</p> <p><b>For B6/Niro</b> DN 150, PN 6           DIN 2573 DN 150, PN 10        DIN 2576</p>	<p><b>0118-271</b> <b>0118-149</b></p> <p><b>0118-222</b> <b>0118-493</b></p>																
<p><b>Discharge flange</b> DIN 2573, DN 65, PN 6</p> <p>for B6/PP for B6/Stainless steel</p>	<p><b>0208-156</b> <b>0208-227</b></p>																
<p><b>Foot strainer</b> Available in PP and stainless steel. Hole diameter 5 mm and 12 mm. For mounting on the pump foot. Keeps impurities away from the rotating parts..</p> <table border="0"> <tr> <td>Pump</td> <td>Hole diameter</td> <td></td> </tr> <tr> <td>B6/PP</td> <td>5 mm</td> <td><b>0118-636</b></td> </tr> <tr> <td></td> <td>12 mm</td> <td><b>0118-148</b></td> </tr> <tr> <td>B6/Stainless steel</td> <td>5 mm</td> <td><b>0118-635</b></td> </tr> <tr> <td></td> <td>12 mm</td> <td><b>0118-237</b></td> </tr> </table>	Pump	Hole diameter		B6/PP	5 mm	<b>0118-636</b>		12 mm	<b>0118-148</b>	B6/Stainless steel	5 mm	<b>0118-635</b>		12 mm	<b>0118-237</b>		
Pump	Hole diameter																
B6/PP	5 mm	<b>0118-636</b>															
	12 mm	<b>0118-148</b>															
B6/Stainless steel	5 mm	<b>0118-635</b>															
	12 mm	<b>0118-237</b>															

# Accessories

## Submersible Centrifugal Pump B6

Product detail	Specification	Order-No.
	<p><b>Connecting cable</b></p> <p>For extension of the connecting line for three-phase motors, 4-wired. According to requirements the cable is available in every necessary length.</p> <p>H07 RN-F, 4 x 1.5 mm<sup>2</sup></p>	<p><b>0336-339</b></p>
	<p><b>Cekon-plug</b></p> <p>5-pole, 16 A for three-phase motors</p>	<p><b>0336-415</b></p>
	<p><b>Lifting device</b></p> <p>To simplify the process of lifting the pump in and out of drums.</p> <p>for three-phase motors</p>	<p><b>0214-196</b></p>
	<p><b>Acid proof coating</b></p> <p>In aggressive atmosphere the three-phase motor should be protected by a special acid proof coating. If customer requires, a special varnish is possible.</p> <p>Acid proof coating Special coating acc. to RAL</p>	<p><b>0006-514</b> <b>0006-515</b></p>



Specification	Order-No.	Product detail
<p><b>Motor protection switch</b></p> <p>Explosion proof according to EEx de IIC T6 with thermal and electromagnetic trip, protection class IP 66. A lifting device and two cable protective coverings are necessary for the mounting.</p> <p>Ex, 2.5 - 4.0 A Ex, 4.0 - 6.3 A</p>	<p><b>0335-419</b> ●</p> <p><b>0335-420</b> ●</p>	
<p><b>Ex-plug</b></p> <p>CEE-round plug in accordance with EEx de IIC T6, splash proof in compliance with IP 65, 5-wired for three phase current.</p> <p>5-pole, IP 65            CEAG 5-pole, IP 65            STAHL</p>	<p><b>0336-537</b> ●</p> <p><b>0336-541</b> ●</p>	
<p><b>Ex-plug</b></p> <p>CEE-socket in accordance with EEx de IIC T6, splash proof in compliance with IP 65, 5-wired for three phase current.</p> <p>5-pole, IP 65            CEAG 5-pole, IP 65            STAHL</p>	<p><b>0336-420</b> ●</p> <p><b>0336-543</b> ●</p>	
<p><b>Equipotential bonding cable</b></p> <p>Serves to create electrically conductive connection between explosion proof pump and container as earthing and equipotential bonding function.</p> <p>2 m long with fastening clip</p>	<p><b>0204-994</b> ●</p>	

# Lutz B80 Vertical Centrifugal Pumps

Durable in service



## Construction benefits

- ✓ Special vapour seals
- ✓ Plain bearing or bearing-less versions available
- ✓ All parts coming into contact with the liquid are made of corrosion resistant plastics
- ✓ Abrasion resistant material combinations possible
- ✓ Wet-well or dry-well installation
- ✓ Immersion depths from 275 to 4000 mm, deeper immersion depths possible using tail pipe
- ✓ Motors from 0.75 kW as per energy efficiency class IE 3 in accordance with EU regulations 640/2009 and 04/2014



## Perfection in plastic

The B80 vertical centrifugal pumps are designed for use in closed, unpressurised containers, pools or excavations.

Special design features enable a long service life and a high level of operational safety. No metal parts come into contact with the fluid being pumped, no housing screws are located in the area of the KGK Series that comes into contact with the medium. A uniformly substantial casing thickness guarantees the highest level of mechanical stability.

Special vapour seals protect the driving elements and surrounding area from gases and vapours.

The product range incorporates 3 basic series of different versions and capacity ranges, all offering the maximum level of component compatibility – the right pump solution for every pumping application.

## High levels of operational safety and low wear

An interlocking coupling is used to transmit power between the motor and the pump. The motors in the KGK Series are equipped with generously dimensioned roller bearings mounted axially and radially. In the directly-coupled KME and HME Series, an innovative 2-piece motor mounting enables rapid access to facilitate maintenance work on the motor and coupling.

The HME Series for dry-well installation featuring a bearing-less cantilever design is used to pump mechanically contaminated fluids and is capable of intermittent dry running.

The motor is safely protected against corrosive acid vapours by a single or double shaft seal. The seal itself does not come into contact with liquids. Liquid flowing up inside the shaft guide tube flows back into the container through overflow holes.

The robust plain bearing fitted in the KGK and KME Series can be made of either PTFE-GF/ceramic or SiC/SiC.

## Applications

Permanently installed pumps are used to pump acid solutions, hydroxides, salts in varying concentrations, strong acid mixtures, galvanising solutions, chemical waste fluids, chlorinated hydrocarbons, glycol ether, emulsions, sea water and hot spring water etc. from containers, tanks, pools, cisterns and pumping pits.

# Lutz B80 Vertical Centrifugal Pumps

Three Series – One Concept



## B80 HME Series

Centrifugal pump for dry-well installation featuring a bearing-less cantilever design with direct-coupled IEC motor. Specially designed for plant engineering and confined spaces.

Flow rate: up to 50 m<sup>3</sup>/h  
Pumping head: up to 40 m  
Installation depth: up to 450 mm



## B80 KME Series

Cost-effective, compact immersion centrifugal pump with plain bearing and directly-coupled IEC motor. Ideal for the low to medium performance segment.

Flow rate: up to 50 m<sup>3</sup>/h  
Pumping head: up to 40 m  
Installation depth: up to 1500 mm



## B80 KGK Series

Powerful and robust immersion centrifugal pump with plain bearing, support stand mounted on roller bearings and IEC standard motor. The KGK Series is designed for medium to high pump capacities under continuous operation.

Flow rate: up to 270 m<sup>3</sup>/h  
Pumping head: up to 85 m  
Installation depth: up to 4000 mm  
additional suction pipe extension up to 2000 mm

# Lutz B80 HME Vertical Centrifugal Pump

Innovative specialists



## Construction benefits

- ✓ Directly-coupled pump featuring an extremely compact design
- ✓ Bearing-less cantilever design, intermittent dry running capability
- ✓ Service-friendly dry-well installation beside the container
- ✓ All parts coming into contact with the liquid are made of corrosion resistant plastics
- ✓ Abrasion resistant material combinations possible
- ✓ Two-piece motor mounting simplifies maintenance work on motor and coupling
- ✓ Vibration-free operation using self-centring guided drive element
- ✓ Short installation length of 275 or 450 mm

## Applications

The extremely compact design and innovative service-friendly 2-part motor mounting combine to make the B80 HME Series ideal for installation in confined spaces. The pump featuring a bearing-less cantilever design is suitable for pumping and circulating neutral, corrosive and mechanically contaminated liquids in stationary installations in the chemical industry and in process engineering, in surface and electroplating engineering and in gas scrubbers. Due to the freely rotating bearing-less shaft and seals in the areas in contact with the medium, the pump is capable of intermittent dry running.

## Dry-well installation

The B80 HME Series can be operated beside the container in a dry-well installation. Liquid flowing up inside the shaft guide tube returns to the container via an overflow line. Pumps in dry-well installations allow easier access to carry out maintenance and repair work.

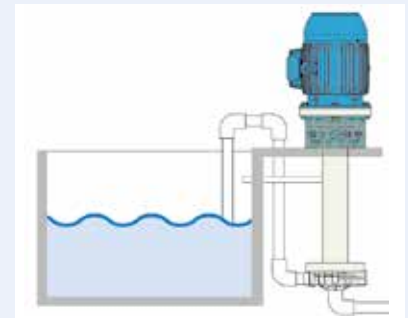

		HME
Flow rate:	m <sup>3</sup> /h	7 to 50
Pumping head:	m	11 to 40
Temperature of pumped medium:	max. °C	90
Density:	max. kg/dm <sup>3</sup>	1.8
Immersion depths:	mm	275 or 450
Dynamic viscosity:	max. mPas	75



# Dry-well Installation Layout

Quick to assemble, easy to operate

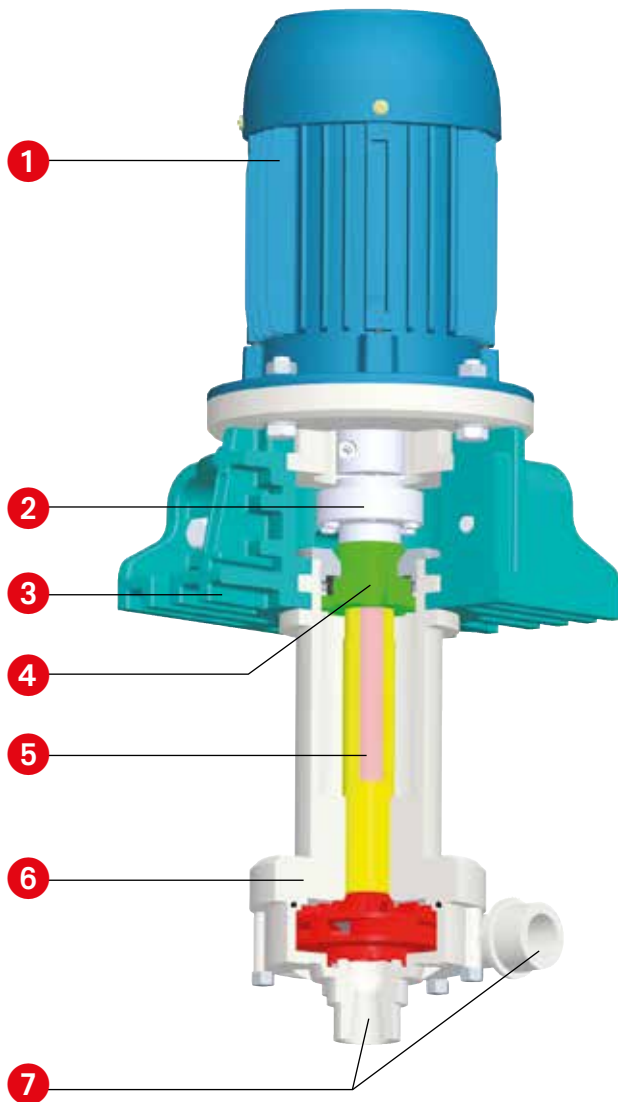

## Innovative construction in detail

**1 Three-phase A.C. motor conforming to IEC standard**

Special voltages and protection classes possible.

**2 Interlocking coupling**

**3 Monoblock motor mounting**

Combining the seating surface and joining element in a single unit suppresses vibrations in the motor and pump. Ideal for installation in confined spaces.

**4 Static-dynamic vapour seal**

An elastomer ring which works when dry and protects the drive elements and the area around the pump from escaping gases and vapours under static and dynamic conditions up to a pressure of 60 mbar.

**5 Pump shaft**

With corrosion-resistant shaft sleeve made of PE or PTFE.

**6 Pump housing and impeller**

Made of chemical-resistant plastics and robust fibreglass or carbon fibre reinforced plastics.

**7 Suction and pressure connection**

Available in either threaded or flanged version.

## Application examples

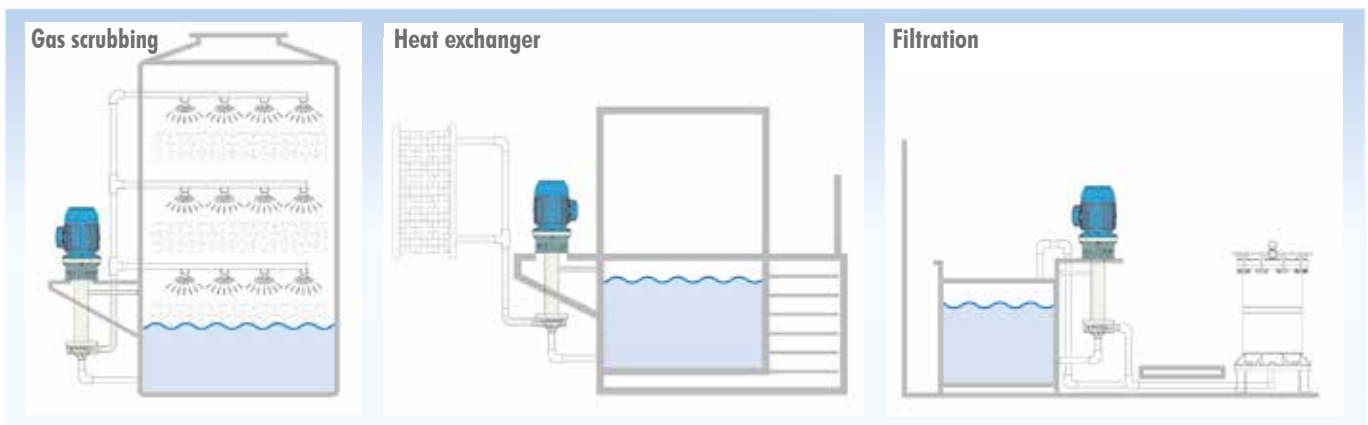

# Lutz B80 KME Vertical Centrifugal Pump

Compact and economical



## Construction benefits

- ✓ Directly-coupled pump featuring an extremely compact design
- ✓ Various plain bearing versions
- ✓ Service-friendly and space-saving construction
- ✓ All parts coming into contact with the liquid are made of corrosion resistant plastics
- ✓ Abrasion resistant material combinations possible
- ✓ Two-piece motor mounting simplifies maintenance work on motor and coupling
- ✓ Vibration-free operation using self-centring guided drive element
- ✓ Immersion depth from 600 to 1500 mm

## Applications

The B80 KME Series was developed as a vertical centrifugal pump for wet-well installation in stationary applications in containers and pools.

The directly-coupled, friction bearing pump is suitable for pumping and circulating neutral and chemically aggressive fluids in the chemical industry and in process engineering, in galvanic and surface engineering, in washing systems and water treatment plants. It can also be used for sump drainage in industrial and municipal waste disposal plants or as a circulation pump in gas scrubbers and heat exchangers.

## Plain bearing

The B80 KME series features an extremely compact design and the innovative 2-piece motor mounting allows for swift access to facilitate maintenance work on the motor and coupling. The pump shaft is completely coated with plastic that is resistant to the pumped medium and is guided behind the impeller by a chemical-resistant and wear-resistant plain bearing.

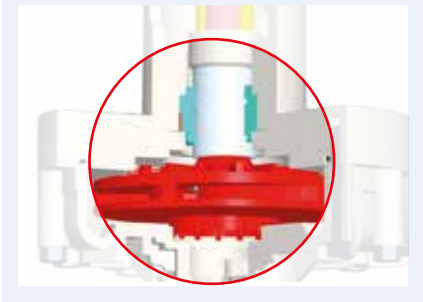

		KME
Flow rate:	m <sup>3</sup> /h	7 to 50
Pumping head:	m	11 to 40
Temperature of pumped medium:	max. °C	90
Density:	max. kg/dm <sup>3</sup>	1.8
Immersion depths:	mm	600 to 1500
Dynamic viscosity:	max. mPas	75

# Wet-well Installation Layout

The Perfect Solution for Plant Engineering

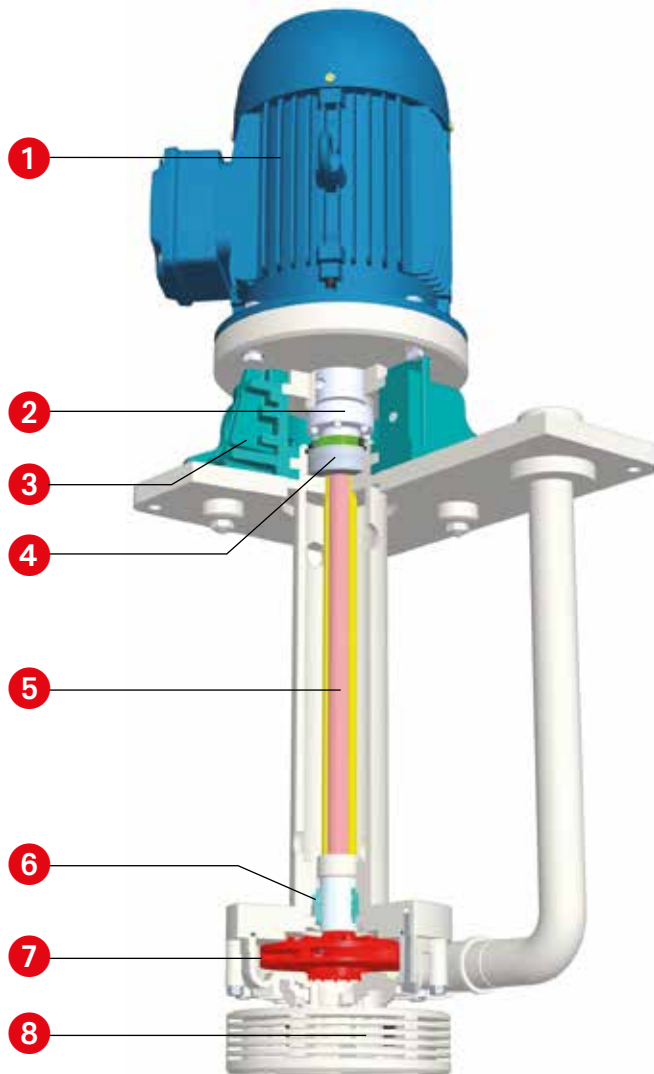

## Innovative construction in detail

- 1 Three-phase A.C. motor conforming to IEC standard**  
Special voltages and protection classes possible.
- 2 Interlocking coupling**
- 3 Monoblock motor mounting**  
Combining the seating surface and joining element in a single unit suppresses vibrations in the motor and pump.
- 4 Static-dynamic vapour seal**  
Protects the drive elements and the area around the pump from escaping gases and vapours under static and dynamic conditions up to a pressure of 60 mbar.
- 5 Pump shaft**  
With corrosion-resistant shaft sleeve made of PE or PTFE.
- 6 Bearing bush housing with plain bearing**  
Optionally in PTFE/glass on ceramic (PTFE/ $\text{Al}_2\text{O}_3$ ) for general applications or SiC/SiC for abrasive media, strong lyes and fluorides, etc.
- 7 Pump housing and impeller**  
Made of chemical-resistant plastics and robust fibreglass or carbon fibre reinforced plastics.
- 8 Filter (optional)**  
Foot strainer with 3 mm passages as an accessory.

## Application examples

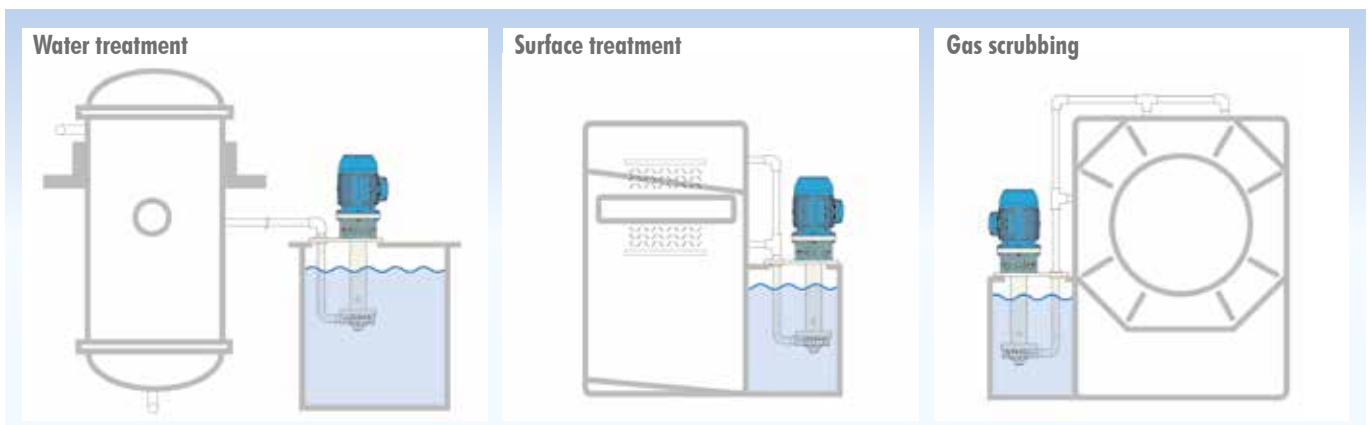

# Lutz B80 HME-KME Vertical Centrifugal Pump

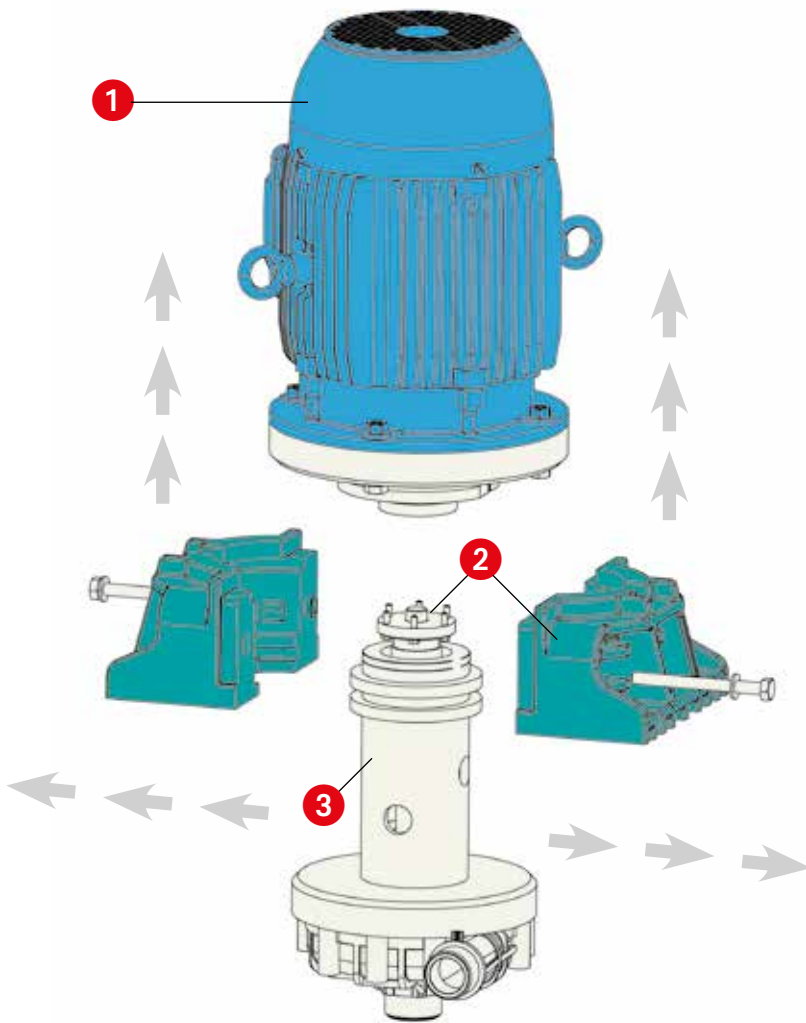

## 1 IEC standard motor

400V, 50-60 Hz, IP 55 and insulation class F available in the following versions:

**N** (for max. density 1.1 kg/dm<sup>3</sup>)

**P** (for max. density 1.35 kg/dm<sup>3</sup>)

**S** (for max. density 1.8 kg/dm<sup>3</sup>)

## 2 Coupling and motor mounting

The interlocking coupling is radially and axially fixed in a self-centring position between the halves of the motor mounting.

The 2-piece monoblock motor mounting allows for swift and simple connection and separation of motor and pump during service and maintenance work.

## 3 Pump housing and impeller

available in two material variants

**WR:** The material used is PP (polypropylene) offering resistance to a broad spectrum of chemicals. The pump hydraulics reinforced with fibreglass offers good mechanical strength and excellent thermal stability.

**FC:** The material used is PVDF (polyvinylidene fluoride), which combines outstanding chemical resistance and excellent resistance to abrasion and mechanical loading. Reinforcing the pump hydraulics with carbon fibres ensures excellent dimensional accuracy and thermal stability without restricting its chemical resistance.

## Materials

Version	WR	FC
Pump housing	PP/GF	PVDF/CF
Impeller	PP/GF	PVDF/CF
Shaft sleeve	PP	PTFE
Shaft guide tube/lifting tube	PP	PVDF
Suction-/pressure connection	PP	PVDF
Bearer plate	PP	PP
Motor mounting	PP/GF	PP/GF
Seals	FKM/EPDM	FKM/EPDM
Bolts coming into contact with the liquid	PVDF	PVDF

## Immersion depth

Series	
HME	275 or 450 mm
KME	600, 800, 1000, 1250 or 1500 mm



## Performance curve with nominal speed at 50 Hz, 2900 rpm.

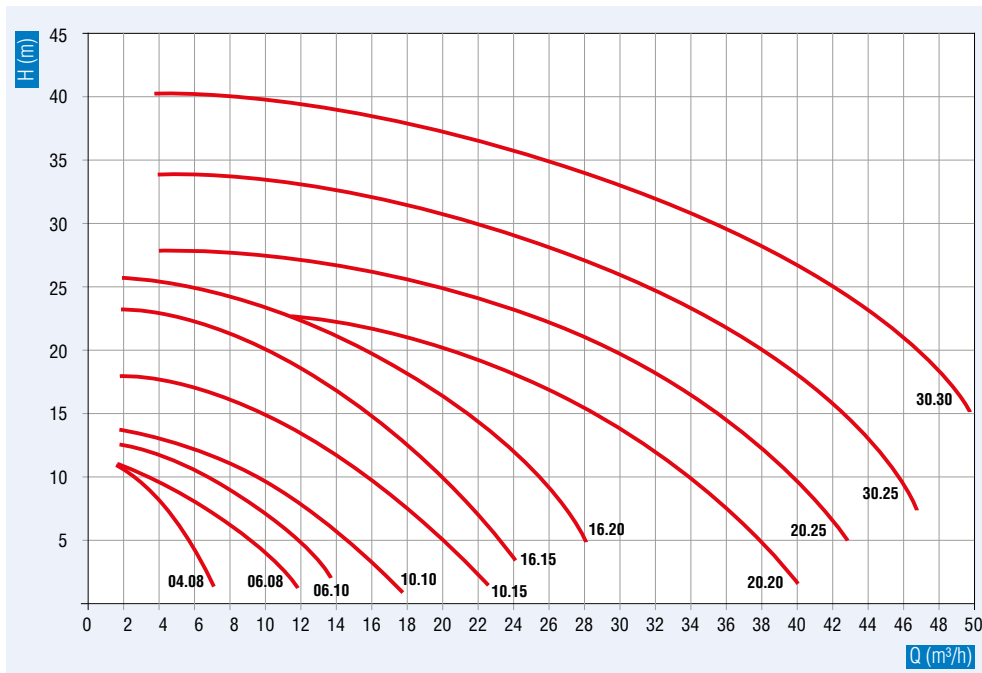

## Temperature limits in °C, depending upon the immersion depth

Version	HME				KME			
Immersion depth in mm	275	450	600	800	1000	1250	1500	
Temperature of pumped medium in °C								
WR		70			65	55	50	
FC		90			85	75	65	
Ambient temperature in °C								
WR			0 to 40					
FC			-10 to 40					0 to 40

## Motor versions and connections

Size		04.08			06.08			06.10			10.10			10.15			16.15			16.20			20.20			20.25			30.25			30.30		
Motor version		N	P	S	N	P	S	N	P	S	N	P	S	N	P	S	N	P	S	N	P	S	N	P	S	N	P	S	N	P	S	N	P	S
Motor power (IEC) 50 Hz	kW	-	0.37	0.55	0.37	0.55	0.75	0.55	0.75	1.1	0.75	1.1	1.5	1.1	1.5	2.2	1.5	2.2	3	2.2	3	4	3	4	5.5	4	5.5	7.5	5.5	7.5	-	7.5	-	-
Density max.	kg/dm <sup>3</sup>	-	1.35	1.8	1.1	1.35	1.8	1.1	1.35	1.8	1.1	1.35	1.8	1.1	1.35	1.6	1.1	1.35	1.8	1.1	1.35	1.8	1.8	1.35	1.8	1.1	1.35	1.8	1.1	1.35	-	1.1	-	-
Inlet	BSP	G 1 OT			G 1 1/4 OT			G 1 1/4 OT			G 1 1/2 OT			G 1 1/2 OT			G 1 1/2 OT			G 1 1/2 OT			G 2 OT			G 2 OT			G 2 OT			G 2 OT		
	ISO (DN)	25			32			32			40			40			40			40			50			50			50			50		
Outlet HME	BSP	G 1 OT			G 1 1/4 OT			G 1 1/4 OT			G 1 1/4 OT			G 1 1/4 OT			G 1 1/4 OT			G 1 1/4 OT			G 1 1/2 OT			G 1 1/2 OT			G 1 1/2 OT			G 1 1/2 OT		
	ISO (DN)	25			32			32			32			32			32			32			40			40			40			40		
Outlet KME	BSP	G 3/4 OT			G 3/4 OT			G 1 OT			G 1 OT			G 1 OT			G 1 1/4 OT			G 1 1/4 OT			G 1 1/2 OT			G 1 1/2 OT			G 1 1/2 OT			G 1 1/2 OT		
	ISO (DN)	20			20			25			25			25			32			32			40			40			40			40		
Motor		3 phases 400 V / 50 Hz, IP 55 (1 phase 230 V / 50 Hz < 3 kW)																																

OT = Outer thread

# Lutz B80 KGK G1/G2 Vertical Centrifugal Pump

Durable in service



## Construction benefits

- ✓ Various plain bearing versions
- ✓ External flushing of plain bearing (optional)
- ✓ All parts coming into contact with the liquid are made of corrosion resistant plastics
- ✓ Abrasion resistant material combinations possible
- ✓ Roller bearings protected from corrosive vapours and gases
- ✓ Vibration-free operation
- ✓ Long service life and high level of operational safety
- ✓ Immersion depth up to 4000 mm and additional suction pipe extension up to 2000 mm

## Construction

The B80 vertical centrifugal pumps have an immersion depth between 500 and 4000 mm in steps of 250 mm. The pump is equipped with a single-stage spiral housing with a closed or open impeller.

The medium is pumped out of the container via the pump outlet and the vertical lifting tube. The downward-facing axial inlet to the pump is equipped with a filter as standard.

## Bearing assembly

The KGK Series is designed for applications with continuous operation. The cast iron bearing housings hold the shaft and compensate for all radial and axial forces.

A torsionally elastic, interlocking coupling is used to transmit power between the motor and the pump.

The pump motor uses generously dimensioned axial and radial roller bearings with lifetime grease lubrication.

Type	G1	G2
<b>C25/100</b>	●	
<b>C25/120</b>	●	
<b>C32/120</b>	●	
<b>C32/140</b>		●
<b>C32/160</b>		●
<b>A40/100</b>		●
<b>A40/120</b>		●
<b>C40/140</b>		●
<b>C40/160</b>		●
<b>A50/100</b>		●
<b>A50/120</b>		●
<b>A50/140</b>		●

C = closed impeller    A = open impeller

		KGK G1	KGK G2
Flow rate:	m <sup>3</sup> /h	18 to 30	24 to 80
Pumping head:	m	13 to 27.5	22 to 41
Temperature of pumped medium:	max. °C	90	90
Density:	max. kg/dm <sup>3</sup>	2	2
Immersion depths:	mm	500 to 4000	500 to 4000
Suction pipe extension:	mm	up to 2000	up to 2000
Dynamic viscosity:	max. mPas	75	75

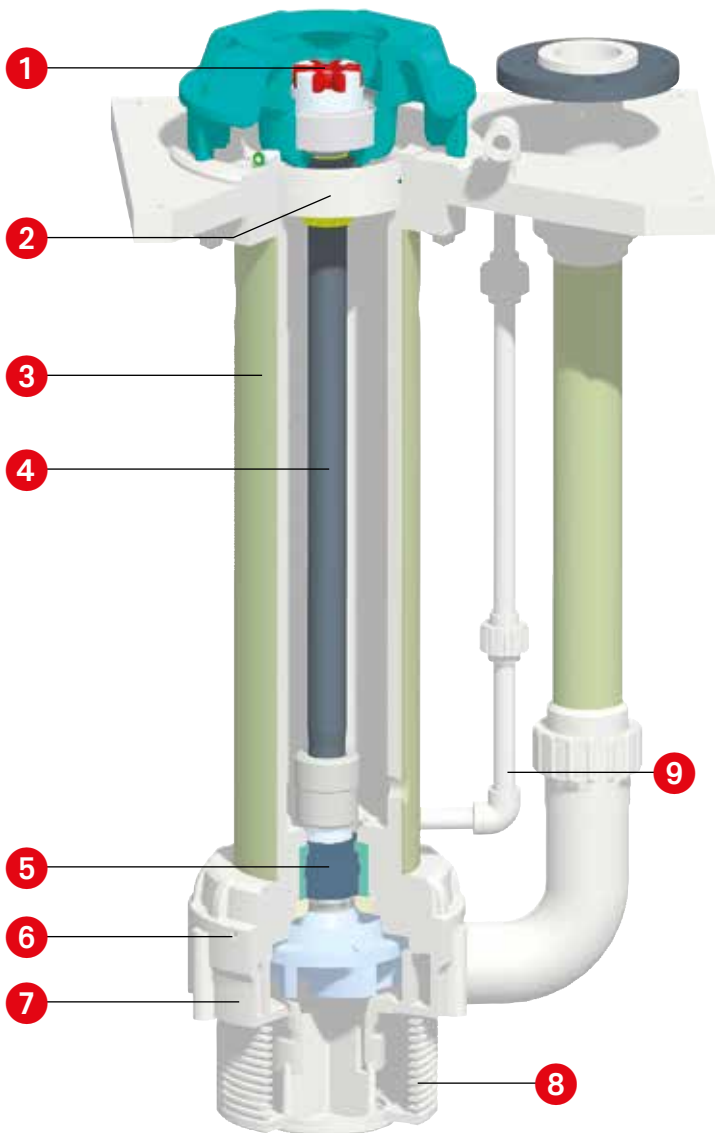

**1 Flexible coupling**

allows swift disassembly of the coupling and drive motor. Excellent dimensional accuracy and close radial tolerances ensure vibration-free operation.

**2 Vapour seal**

protects the drive elements and the area around the pump under static and dynamic conditions from escaping gases and vapours.

**3 Shaft guide tube/lifting tube**

made of chemically resistant plastics. For the "G" version, with additional GRP reinforcement (vinyl-ester-reinforced fibreglass).

**4 Pump shaft**

with corrosion-resistant shaft sleeve made of PE or PTFE.

**5 Bearing bush housing with plain bearing**

Simple replacement of the plain bearing

**6 Casing connection via central ring nut**

No housing screws in the area of the pump that comes into contact with the medium, exact positioning of the pump housing with respect to the discharge manifold.

**7 Pump housing and impeller**

made of chemical-resistant plastics and robust fibreglass or carbon fibre reinforced plastics.

**8 Filter**

Foot strainer as standard, with 3 mm passages.

**9 External flushing pipe (optional)**

for external flushing of the guide bushes when pumping fluids containing solids.

## Application examples

Sump drainage

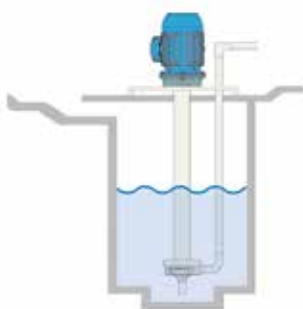

Tank drainage

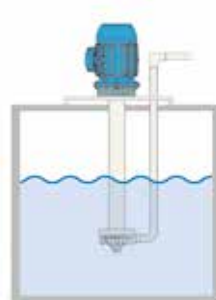

Gas scrubbing

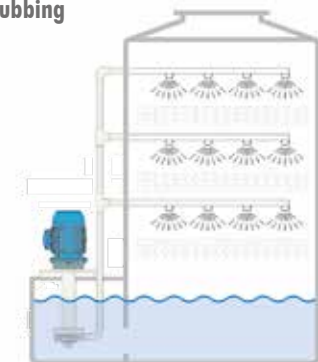

# B80 KGK G1/G2 Lutz Vertical Centrifugal Pump

Conserves the environment and your budget

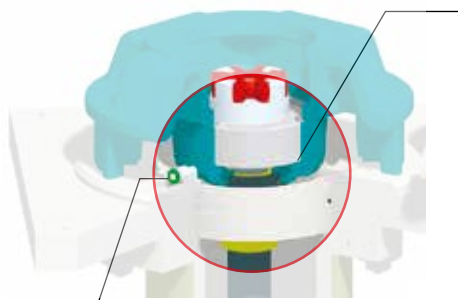

## Vapour seal

To contain the vapours and gases which arise inside the pump, a dry vapour seal that works both in static and dynamic conditions is fitted at the height of the bearer plate in the standard version. In addition to the standard lip seals which work dry, a mixed seal is also available which has a dynamic deflector ring that works efficiently up to a pressure of about 100 mbar.

**The innovative "liquid barrier" system** can be supplied with compressed air or liquid via a rapid-action coupling. The laminar spread of the compressed air builds up a counter-pressure, completely blocking poisonous vapours and gases so these can neither reach the mechanical parts nor escape to the outside, thus protecting the environment.

## Rapid-action coupling

Supply connection for the "liquid barrier"

## Vapour seal versions

### VR - static-dynamic (standard):

An elastomer ring which works when dry and is guaranteed not to leak up to a pressure of around 60 mbar under both static and dynamic conditions.

### VF - Liquid barrier (optional):

Externally supplied low pressure flow of air or liquid, which spreads in a laminar fashion and which presents an effective barrier to gases and vapours (max. 200 mbar).

### VL - (optional) in combination with the standard version:

Using a dynamic deflector ring, an increased pressure of up to approx. 100 mbar is permitted.

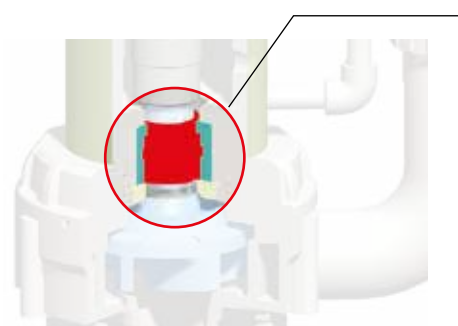

## Guide system for the pump shaft

The pump shaft is completely coated with plastic that is resistant to the pumped medium. The shaft is guided at the top by a roller bearing and then along its length by plain bearings. For immersion depths up to 2000 mm, a single lower guide after the impeller is sufficient. For deeper immersion depths, an additional intermediate guide is installed.

## Bearing assembly

Plain bearings made of PTFE/glass on ceramic (PTFE/Al<sub>2</sub>O<sub>3</sub>) for general applications or SiC/SiC for abrasive media can be specified as options.

The plain bearings are lubricated by the pumped medium or can be supplied with an external medium as an option.



Performance curve with nominal speed at 50 Hz, 2900 rpm.

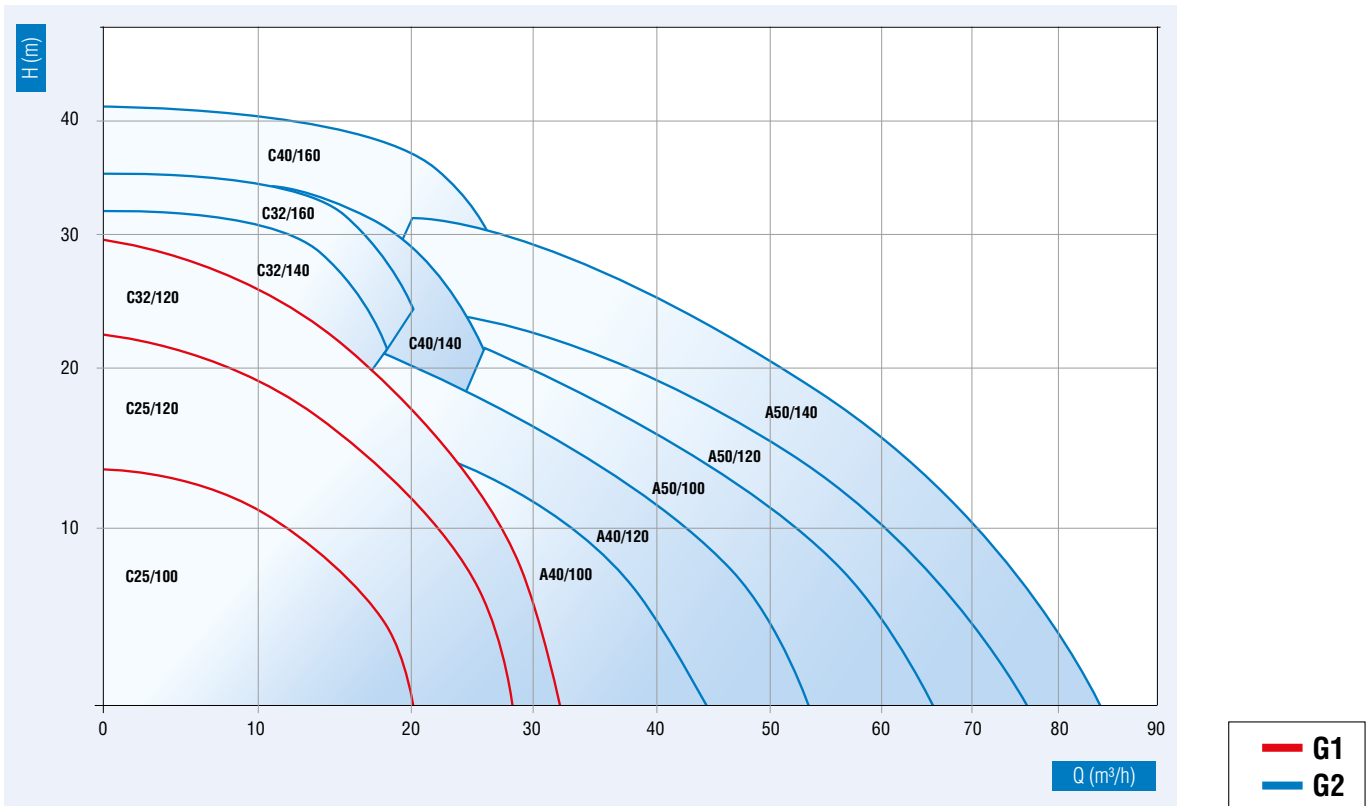

Performance curve with nominal speed at 50 Hz, 1450 rpm.

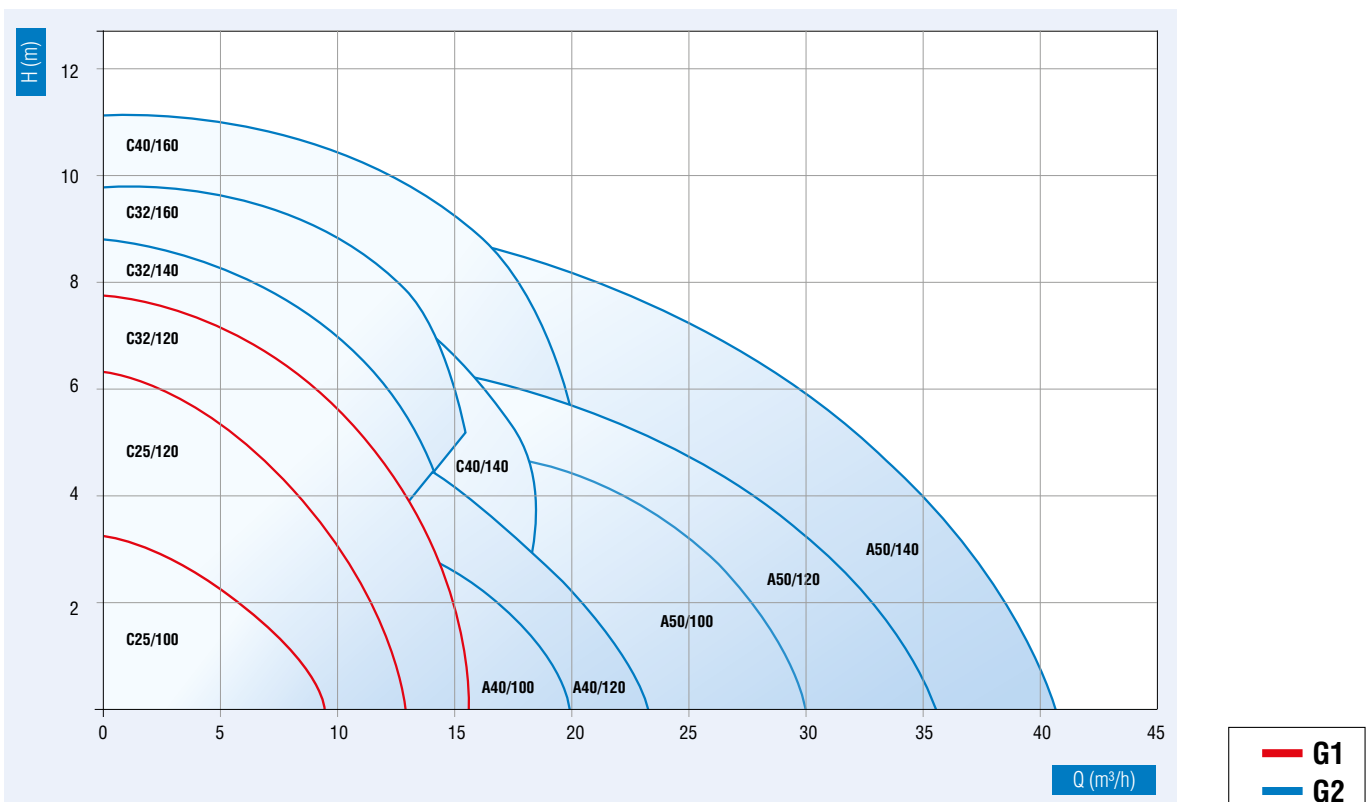

# Lutz B80 KGK G3 Vertical Centrifugal Pumps

Built for the toughest pumping tasks



## Construction benefits

- ✓ External flushing of plain bearing (optional)
- ✓ All components coming into contact with the medium are made of corrosion-resistant plastic, also available in abrasion-resistant material combinations
- ✓ Efficient and space-saving construction using single and two-stage pump hydraulics
- ✓ Roller bearings protected from corrosive vapours and gases
- ✓ Vibration-free operation
- ✓ Long service life and high level of operational safety
- ✓ Immersion depth up to 4000 mm and additional suction pipe extension up to 2000 mm
- ✓ Motors from 0.75 kW as per energy efficiency class IE 3 in accordance with EU regulations 640/2009 and 04/2014

## Designed for industrial applications

The B80 KGK G3 vertical centrifugal pumps are designed for industrial applications in closed, unpressurised containers, pools or excavations.

Special design features enable a long service life and a high level of operational safety. No metal parts come into contact with the fluid being pumped, no housing screws are located in the area of the pump that comes into contact with the medium. A uniformly substantial casing thickness guarantees the highest level of mechanical stability.

Special vapour seals protect the driving elements and surrounding area from gases and vapours. Alternatively, a floating ring seal lubricated with the medium is available.

The B80 KGK G3 Series incorporates 18 pump sizes of different versions and capacity ranges, all offering the maximum level of component compatibility – the right pump solution for every pumping application.

## Construction

The G3 Series is available in single- or two-stage versions equipped with one or two impellers for high pump capacities. The special geometry of the pump hydraulics minimises vibrations and radial loading of the bearing system.

An elastic coupling is used to transmit power from the motor to the pump. The motors in the KGK Series are equipped with generously dimensioned, oil lubricated roller bearings mounted axially and radially. The motor is safely protected against corrosive acid vapours by a single or double shaft seal.

The medium is pumped out of the container via the pump outlet and the vertical lifting tube. The plain bearing that comes into contact with the liquid is made of PTFE-GF/ceramic or SiC/SiC as an option. Liquid flowing up inside the shaft guide tube returns to the container through balancing holes. The downward-facing axial inlet to the pump is equipped with a filter as standard.

## Applications

Permanently installed pumps are used to pump acid solutions, hydroxides, salts in varying concentrations, strong acid mixtures, galvanising solutions, chemical waste fluids, chlorinated hydrocarbons, glycol ether, emulsions, sea water and hot spring water etc. from containers, tanks, pools, cisterns and pumping pits.

# Lutz B80 KGK G3 Vertical Centrifugal Pumps

Type	G3	
	2900	1450
Speed rpm	2900	1450
C40/180	●	
C40/200	●	
C50/160	●	●
D50/160		●
C50/200	●	●
D50/200		●
C65/160	●	●
D65/160		●
C65/200	●	●
D65/200		●
C80/160	●	●
D80/160		●
C80/200		●
D80/200		●
C100/160		●
D100/160		●
C100/200		●
D100/200		●

C = closed impeller

D = closed impeller, 2-stage



## Single- and Two-stage Pumps

The B80 KGK G3 Series incorporates two different hydraulic designs. Depending on the application and the required performance range, either a single-stage spiral housing with a closed impeller or a two-stage version featuring two impellers arranged behind one another are used.

Multi-stage pumps are used to increase the delivery pressure while retaining the compact dimensions of the hydraulic system and are used in particular for processes involving high delivery pressures and low delivery rates. The minimal space required compared with similar single-stage pumps with larger impeller diameters is particularly advantageous for restricted installation conditions.

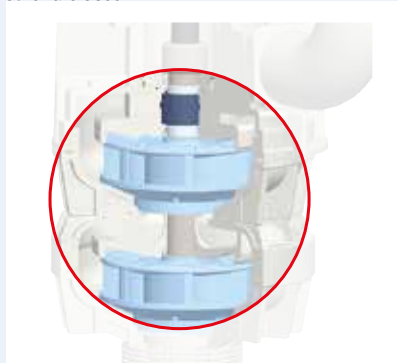

		G3
Flow rate:	m <sup>3</sup> /h	60 up to 270
Pumping head:	m	13 up to 85
Temperature of pumped medium:	max. °C	90
Density:	max. kg/dm <sup>3</sup>	2
Immersion depths:	mm	500* up to 4000
Suction pipe extension:	mm	bis 2000
Dynamic viscosity:	max. mPas	75

\* 500 mm only single-stage pumps

# Lutz B80 KGK G3 Vertical Centrifugal Pumps

Innovative construction in detail

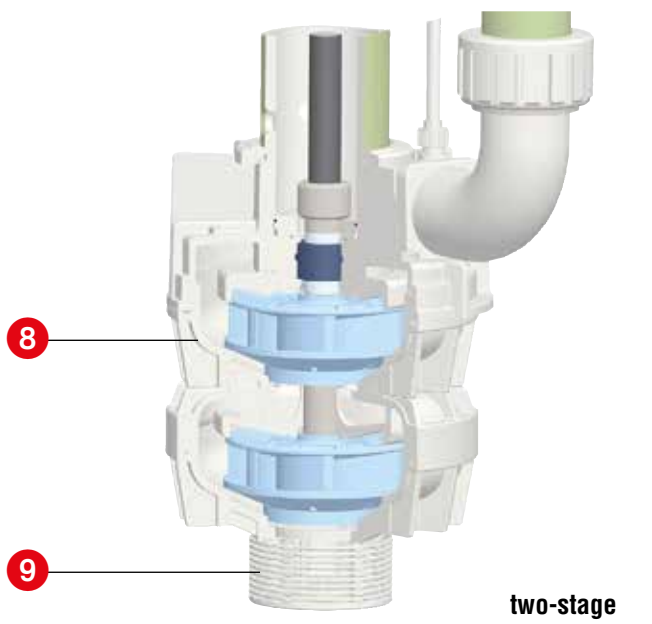
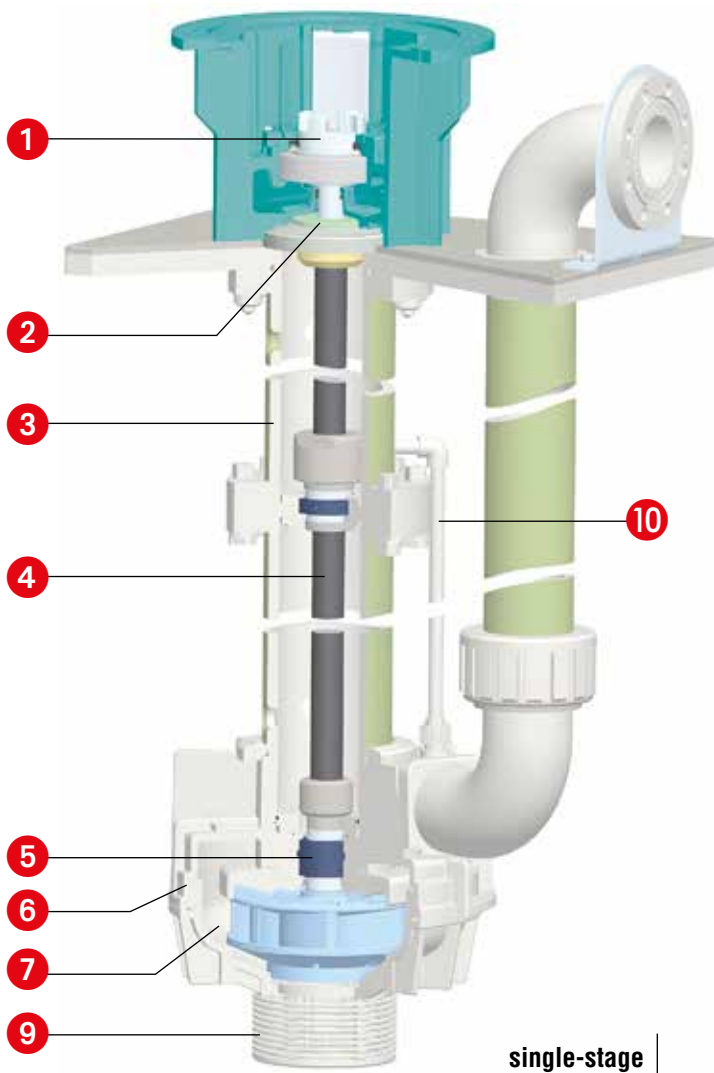

## 1 Flexible coupling

Swift disassembly of the coupling and drive motor. High level of dimensional accuracy and close radial tolerances ensure vibration-free operation.

## 2 Vapour seal

Protects the drive elements and the area around the pump from escaping gases and vapours under static and dynamic conditions.

## 3 Shaft guide tube/lifting tube

Made of chemically resistant plastics in the "G" version with additional GRP reinforcement (vinyl-ester-reinforced fibreglass).

## 4 Pump shaft

With corrosion-resistant shaft sleeve made of PE or PTFE

## 5 Bearing bush housing with plain bearing

Simple replacement of the plain bearing

## 6 Casing connection via central ring nut

No housing screws in the area of the pump that comes into contact with the medium, exact positioning of the pump housing with respect to the discharge manifold.

## 7 Pump housing and impeller (single-stage)

With optimized flow characteristics, made of chemical-resistant and robust fibreglass or carbon fibre reinforced plastics.

## 8 Pump housing and impeller (two-stage)

Featuring a compact, clearly structured in-line configuration. Double the delivery head at a constant flow rate.

## 9 Filter

Foot strainer as standard with 3 mm passages to protect the pump against coarse contaminants.

## 10 External flushing pipe (optional)

For external flushing of the guide bushes when pumping solid containing fluids.

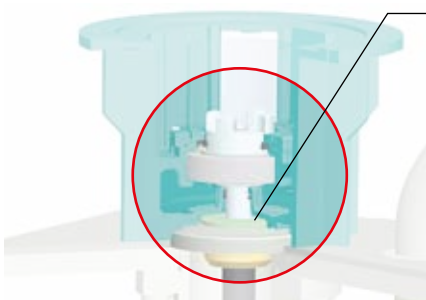

### Vapour seal

To contain the vapours and gases which arise inside the pump, a dry vapour seal works both in static and dynamic conditions is fitted at the height of the bearer plate in the standard version. In addition to the standard lip seals which work dry, a mixed seal is also available which has a dynamic deflector ring that works efficiently up to a pressure of about 100 mbar.

**The innovative "liquid barrier" system** can be supplied with compressed air or liquid via a rapid-action coupling. The laminar spread of the compressed air builds up a counter-pressure, completely blocking poisonous vapours and gases so these can neither reach the mechanical parts nor escape to the outside, thus protecting the environment.

### Vapour seal versions

#### VR - static-dynamic (standard):

An elastomer ring which works when dry and is guaranteed not to leak up to a pressure of around 60 mbar under both static and dynamic conditions.

#### VL - (optional) in combination with the standard version:

Using a dynamic deflector ring, an increased pressure of up to approx. 100 mbar is permitted.

#### VF - Liquid barrier (optional):

Externally supplied low pressure flow of air or liquid, which spreads in a laminar fashion and which presents an effective barrier to gases and vapours (max. 200 mbar).

#### VM - Floating ring seal (optional):

Alternatively, a single-acting slide ring seal lubricated by the pumped medium is available. A large selection of suitable material combinations allows for custom adjustment to the respective application.

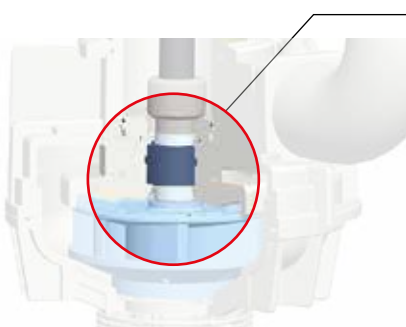

### Guide system for the pump shaft

The pump shaft is completely coated with plastic that is resistant to the pumped medium. The shaft is guided at the top by a roller bearing and then along its length by plain bearings. For immersion depths up to 2000 mm, a single lower guide after the impeller is sufficient. For deeper immersion depths, an additional intermediate guide is installed.

### Bearing assembly

Plain bearings made of PTFE/glass on ceramic (PTFE/Al<sub>2</sub>O<sub>3</sub>) for general applications or SiC/SiC for abrasive media can be specified as options. The plain bearings are lubricated by the pumped medium or can be supplied with an external medium via an external flushing line as an option.

## Application examples

### Sump drainage

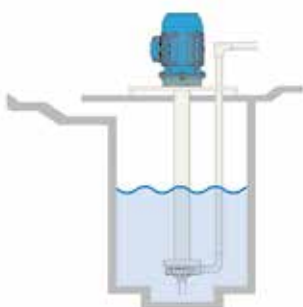

### Tank drainage



### Gas scrubbing

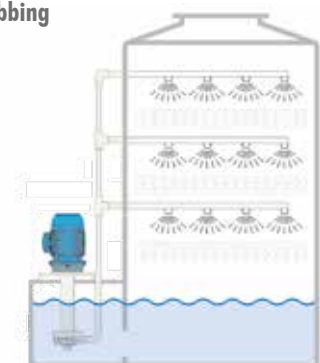



# Lutz B80 KGK G3 Vertical Centrifugal Pump

## Technical data

Performance curve with nominal speed at 50 Hz, 2900 rpm.

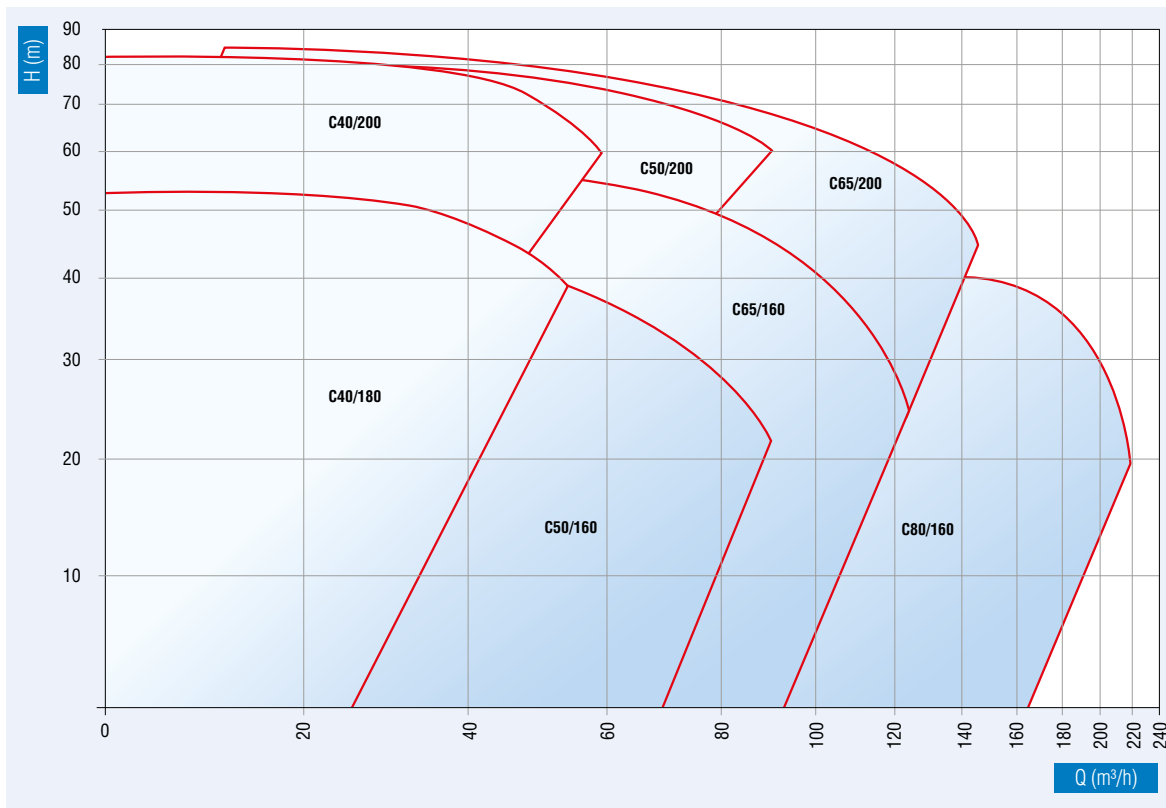

Performance curve with nominal speed at 50 Hz, 1450 rpm.

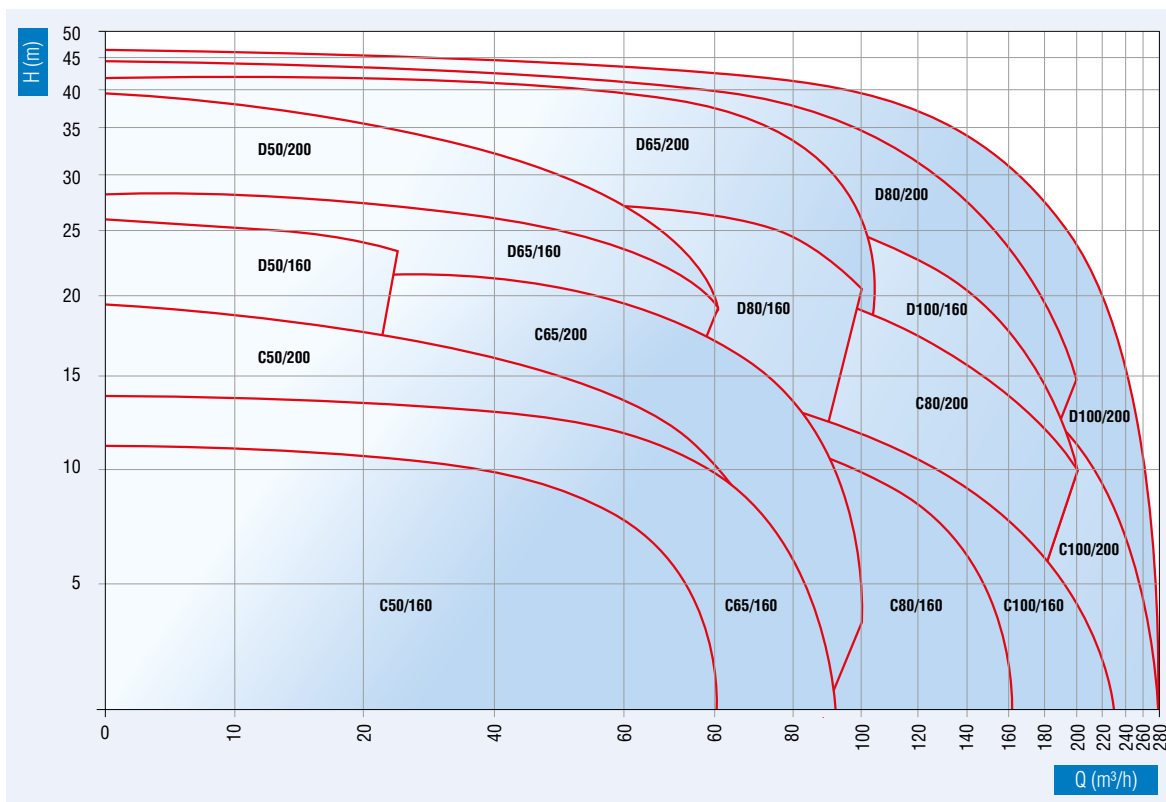

# Lutz B80 KGK G1/G2/G3 Vertical Centrifugal Pump

Technical data

## Materials

The materials in direct contact with the liquid have a high chemical resistance. The WR, FC and WF versions are made of thermoplastic polymer materials or clad with GRP (vinyl-ester-reinforced fibreglass).

To make the correct selection from these materials, the chemical composition of the liquid, its concentration and temperature must be checked to thus enable reliable operation.

## WR - WRG

The material used is PP (polypropylene) with resistance to a broad spectrum of chemicals. The hydraulics of the pump is reinforced with fibreglass and offers good mechanical strength and excellent dimensional accuracy.

## WF - WFG

The material used is PP (polypropylene, partially reinforced with fibreglass). The impeller is made of PVDF, which increases its resistance to wear and abrasion.

## FC - FCG

The material used is PVDF (polyvinylidene fluoride): A fluoroplastic with good resistance to abrasion and high mechanical strength. Reinforcing the pump hydraulics with carbon fibres increases its strength and accuracy of its dimensions without restricting its resistance to chemicals.

## Exceptionally robust construction for version "G"

For the "G" version, the immersed shaft guide tube and the rising tube are coated with GRP (vinyl-ester-reinforced fibreglass). This increases the strength and limits longitudinal expansion due to temperature.

## Motors

### IEC standardised motors

400 V, 50 Hz, IP 55, insulation class F

Motors from 0.75 kW as per energy efficiency class IE 3 in accordance with EU regulations 640/2009 and 04/2014

### Possible immersion depths

#### Variants

WR, WF, FC	500 to 3000 mm
WRG, WFG, FCG	500 to 4000 mm

## Materials

Version	WR	WF	FC	WRG	WFG	FCG
Pump housing	PP/GF	PP/GF	PVDF/CF	PP/GF	PP/GF	PVDF/CF
Impeller	PP/GF	PVDF/CF	PVDF/CF	PP/GF	PVDF/CF	PVDF/CF
Shaft sleeve	PE	PE	PTFE	PE	PE	PTFE
Bearer plate	PP	PP	PP	PP	PP	PP
Shaft guide tube/lifting tube	PP	PP	PVDF	PP/GRP	PP/GRP	PVDF/GRP
Outlet connection	PP	PP	PVDF	PP	PP	PVDF
Bearing housing	Cast iron					
Seals	FKM/EPDM					

## Temperature of the pumped medium in °C, depending upon the immersion depth

Version	WR	WF	FC	WRG	WFG	FCG
500	70	70	90	70	75	80
750	70	70	90	70	75	80
1000	65	65	85	70	75	80
1250	55	55	75	70	75	80
1500	50	50	65	70	75	80
1750	45	45	60	70	75	80
2000	40	40	55	70	75	80
2500	35	35	45	70	75	80
3000	30	30	40	70	75	80
4000	–	–	–	70	75	80

# Lutz Horizontal Centrifugal Pumps

Magnetically coupled



## Fields of application

- ✓ Galvanic and surface processing systems
- ✓ Water treatment and wastewater systems
- ✓ Etching and cleaning systems
- ✓ Printed circuit board manufacturing
- ✓ Chemical industry (general)
- ✓ Galvanic/acid process plant engineering
- ✓ Photo industry
- ✓ Solar system

## Ideally designed for pumping:

Many liquids which include acids, bases, mixtures of acids and bases, solvents, alkali stripping baths, galvanic baths, photo-chemicals as well as radioactive, sterile, expensive or highly corrosive liquids.

## Features

- **Sealless**  
The impeller is driven by the magnetic force of the outer magnets, therefore no mechanical seal is required. As the pump housing is hermetically sealed no leaks can occur.
- **Different bearing systems for different needs**  
Bearing materials of carbon, ceramic, silicon carbide and Rulon® make it possible to configure pumps individually for difficult operating conditions, such as dry running, suspended solids, or highly aggressive media.
- **Operating safety and high level of efficiency**  
The use of high-performance permanent magnets ensures high transmission forces even at elevated temperatures. The design of the bearing system and use of compatible materials reduce energy loss through friction.

## Customer benefits

- ✓ **Power and efficiency**  
Maximum level of efficiency through optimised hydraulics results in lower power requirements.
- ✓ **Long service life**  
The use of high quality materials ensures a long service life.
- ✓ **Highly cost-effective**
- ✓ **Easy to maintain**  
Small number of components and wear parts can be replaced without special tools, thus reducing cost and lengthy downtimes.
- ✓ Motors from 0.75 kW as per energy efficiency class IE 3 in accordance with EU regulations 640/2009 and 04/2014



**Atex:**



The GX version of the AM/TMR series, complies with the requirements of ATEX directive 2014/34/EU. Thus they can be used in hazardous (Ex) areas.



# Lutz Horizontal Centrifugal Pumps

The right solution for every pumping requirement



## TMR G2 / TMR G3 series

With the TMR series, Lutz offers a reliable magnetically coupled pump with a patented magnetic axial thrust self-aligning system that easily handles critical suction conditions caused by pressure loss. When used together with the "R" bearing system, the pumps are suitable for dry running. The series is designed for medium (TMR G2) to large pumping capacity (TMR G3) at higher system pressures.

Pump capacity: up to 48 m<sup>3</sup>/h (800 l/min)  
Pumping head: up to 42 m



## AM series

With a proven track record, the AM series is ideal for transfers with medium flows, circulation and low pressure systems. The glass reinforced polypropylene and ECTFE housing combined with the available choice of bearing materials allow the AM series to be used in a wide range of applications with an 85% coverage of frequently use chemicals.

Pump capacity: up to 200 l/min  
Pumping head: up to 12 m



## TMB series

The TMB series is specially designed for installation in small systems and equipment. The sturdy construction and reduced dimensions make the series suitable for OEM application.

Pump capacity: up to 65 l/min  
Pumping head: up to 8 m

EU-Patent No. 1152151  
US-Patent No. 6,551,075

# Lutz Horizontal Centrifugal Pumps

Pumps are among the most important system components in the chemical and process industries. Safety during operation, reliability and performance are prime considerations, especially when aggressive, corrosive, toxic and other hazardous liquids must be pumped. Don't take chances – contact your Lutz partner or us directly.

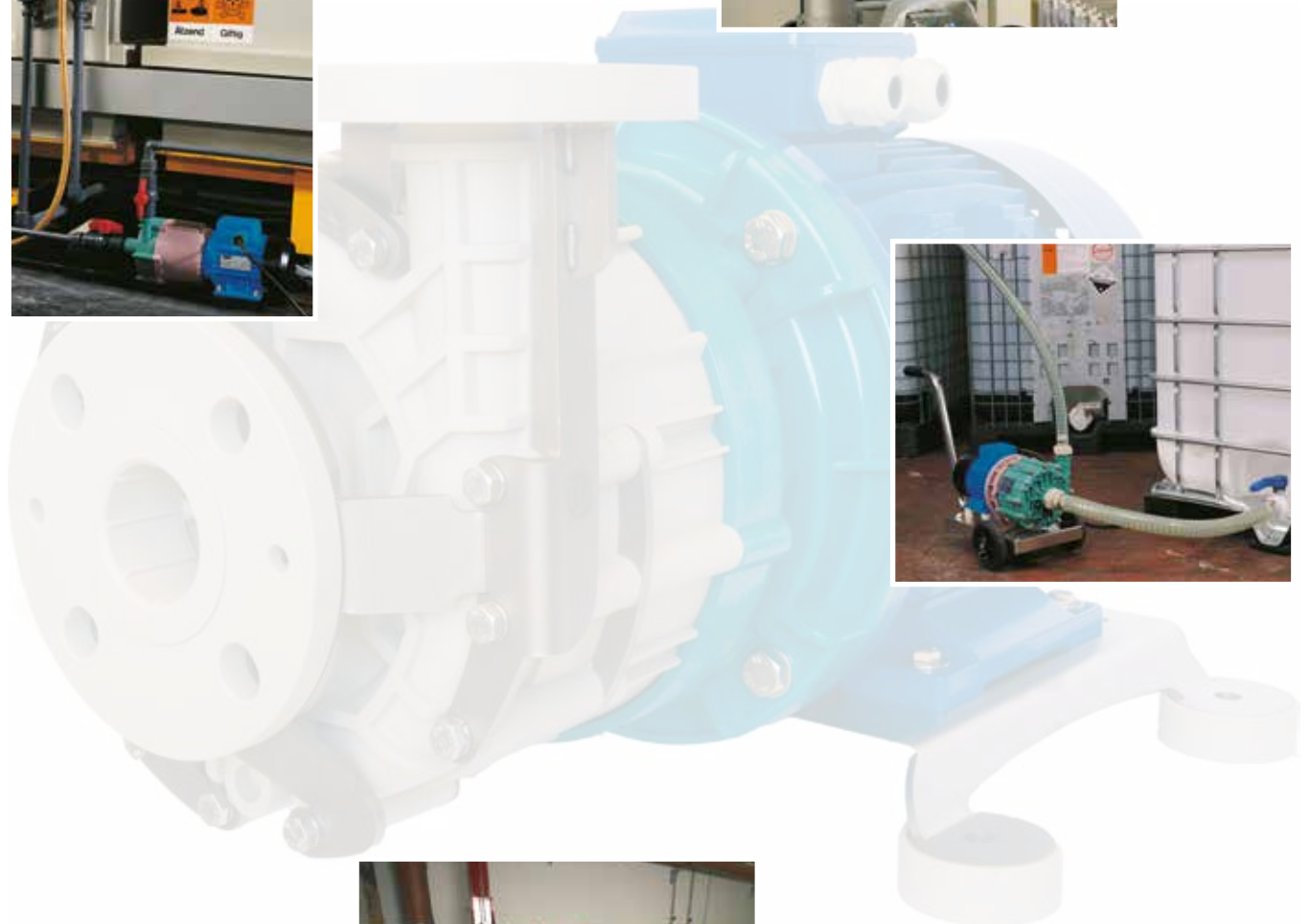



# Lutz Horizontal Centrifugal Pumps

Leak-free and reliable

## Operating principle

The magnetic coupling consists of two magnetic rotors separated from each other by a closed rear casing. The drive magnetic rotor positioned on the motor shaft transfers the torque of the motor via a rotating magnetic field to the inner rotor enclosed in the rear casing. Depending on the pump design, the driven rotor is directly or indirectly connected with the impeller. Thus the impeller is driven without the need of a shaft seal. The pumped liquid lubricates the bearing of the pump. A static seal between the pump housing and the separate rear casing acts as a sealing element to the atmosphere.

Lutz horizontal centrifugal pumps with magnetic coupling are running leakage- and maintenance-free.

- 1 Pump housing
- 2 Impeller with magnet
- 3 Front bushing
- 4 Rear casing
- 5 Rear bushing
- 6 O-Ring
- 7 Drive magnet
- 8 Bracket
- 9 Housing bolts

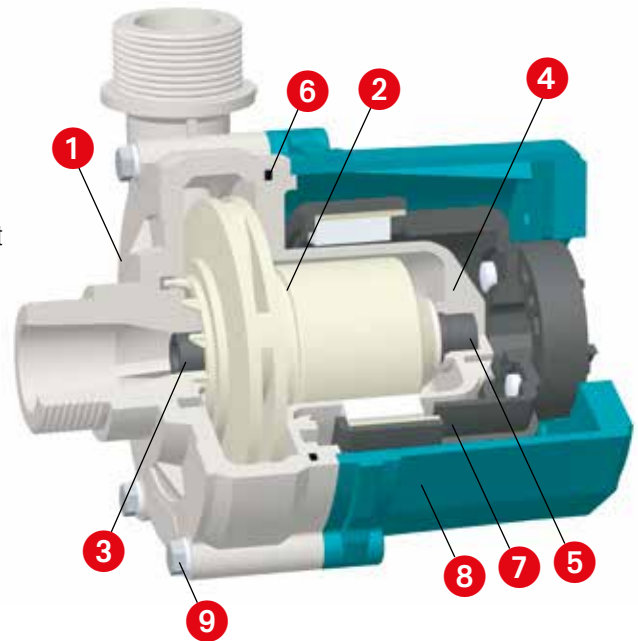

## Exploded view

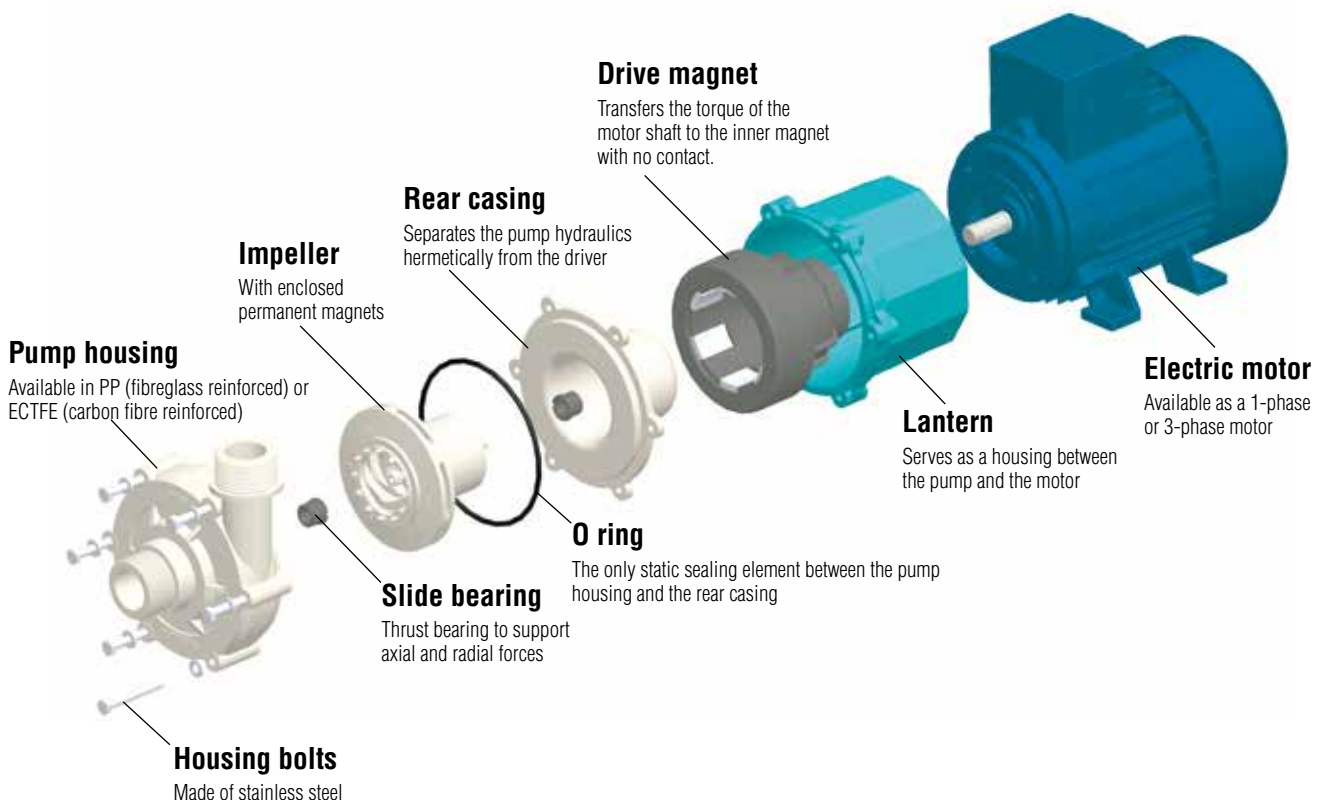



# Lutz Horizontal Centrifugal Pumps

TMB Series: Rugged technology in a minimum of space

✓ **Compact dimensions, performance according to the needs**

TMB range gives up to 62 l/min. and max. 8m delivery head, ideal for small systems and apparatus engineering. Covers densities up to 1.1 kg/dm<sup>3</sup> and viscosities up to 20 mPas.

✓ **Corrosion resistant**

Bearings made from Rulon®, adequate for bromine and chromium compounds.

✓ **Ideal for mobile applications**

In mobile apparatuses.

✓ **Variable connections possibilities**

Various threads and flanges are possible.



### Pump construction

- **Pump material**  
**WR:** Polypropylene (glass fibre reinforced)  
**GF:** ECTFE (carbon fibre filled)
- **Bearing material**  
Rulon®, ceramics
- **Sealing of casing**  
FPM
- **Magnet**  
Ferrite

## Bearing system TMB



### Corrosion resistant

Adequate for bromine and chromium compounds through the use of **Rulon®** slide bearings

### Performance curve

Single performance curve in 50 Hz and 60 Hz on request.

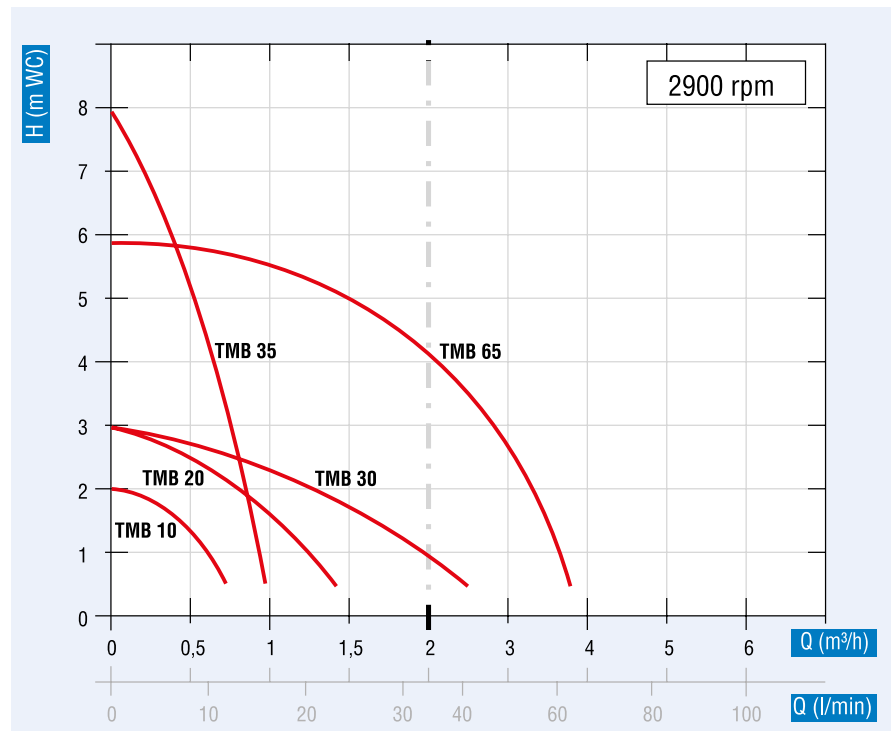

Type	TMB 10	TMB 20 - 30 - 35 - 65	TMB 35
<b>Construction</b>	<b>WR</b>	<b>WR</b>	<b>GF</b>
Volute casing	Polypropylene (glass fibre reinforced)	Polypropylene (glass fibre reinforced)	ECTFE
Rear casing			(carbon fibre filled)
Centrifugal impeller			
Operating temperature	0 up to +60 °C	0 up to +60 °C	0 up to +110 °C
Environment temperature	0 up to +45 °C	0 up to +45 °C	0 up to +45 °C
<b>Bearing system</b>	<b>N<sub>1</sub></b>	<b>N<sub>1</sub></b>	<b>N<sub>1</sub></b>
Guide bearing	–	Rulon®	Rulon®
Shaft	SS	ceramics	ceramics
Thrust ring	Rulon®	ceramics	ceramics
O ring	FPM	FPM	FPM
Screws	SS	SS	SS

Technical data		TMB 10	TMB 20	TMB 30	TMB 35	TMB 65
Inlet-∅	BSP	–	G 3/4 OT	G 3/4 OT	G 1/2 OT	G 1 OT
Outlet-∅	BSP	–	G 3/4 OT	G 3/4 OT	G 3/8 OT	G 1 OT
Hose connection	Inlet (mm)	14	18*	20*	18*	26*
	Outlet (mm)	14	17*	20*	18*	26*
Motor power (IEC) 50 Hz	W	15	29	57	57	97
Motor		1-Phase 230 V / 50 Hz				

Rulon® is a registered Trademark of Saint-Gobain. OT = Outer thread IT= Inner thread

\*on request

# Lutz Horizontal Centrifugal Pumps

AM Series: Compact and versatile for small quantities

✓ **Small pump sizes, high performance**

The AM series achieves up to 200 l/min., max. 12 m delivery head with compact dimensions, densities up to 1.8 kg/dm<sup>3</sup> and viscosities up to 40 mPas.

✓ **Dry running**

The R<sup>+</sup> version is suitable for limited dry running (Version WR and GF)

✓ **Corrosion resistant**

Version N<sup>+</sup> adequate for bromine and chromium compounds.

✓ **Low downtimes**

Version X<sup>+</sup> up to 5% solids possible.

✓ **Variable connection possibilities**

Various hoses, threads and flanges are possible.

✓ **Also suitable for combustible media**

Design GX approved according to ATEX.



**Pump construction**

- **Pump material**  
**WR:** Polypropylene (glass fibre reinforced)  
**GF/GX:** ECTFE (carbon fibre filled)
- **Bearing material**  
 Carbon, ceramics, silicon carbide, Rulon®
- **Sealing of casing**  
 FPM, EPDM or FFPM
- **Drive magnet**  
 Neodymium-Iron-Boron

## Bearing systems AM

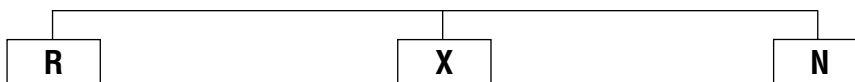

**Designed for dry running**

Designed for dry running through the use of **HD carbon** slide bearings



**Adequate for solids**

Adequate for solids through the use of **silicon carbide** slide bearings



**Corrosion resistant**

Adequate for bromine and chromium compounds through the use of **Rulon®** slide bearings

Rulon® is a registered Trademark of Saint-Gobain.

### Performance curve

Single performance curve in 50 Hz and 60 Hz on request.

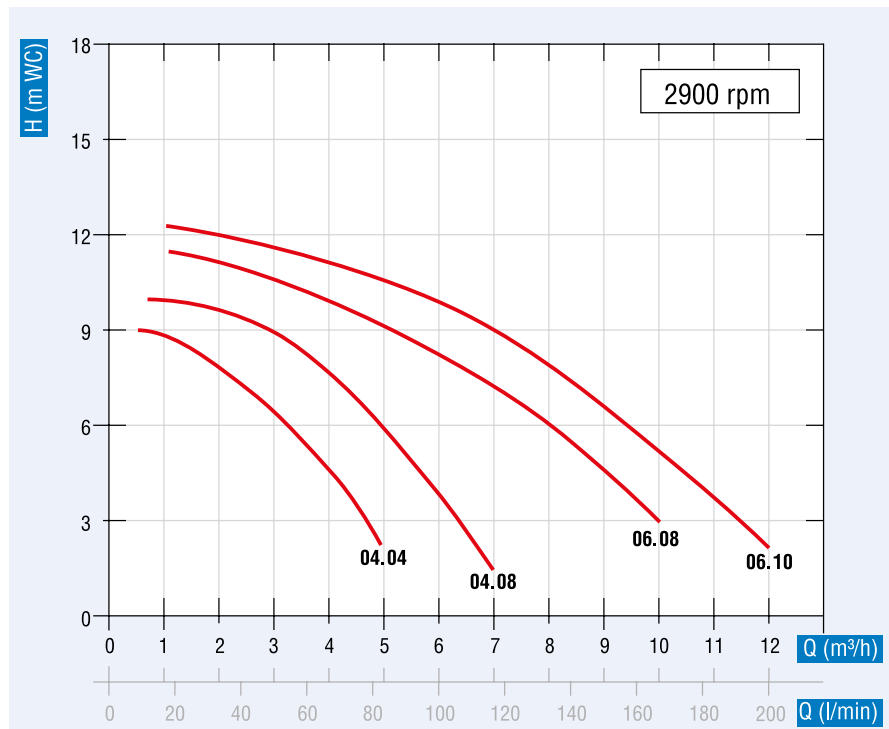

Type	WR			GF			GX	
Category 2 (acc. to ATEX)	no			no			yes	
Volute casing	Polypropylene			ECTFE			ECTFE	
Rear casing	(glass fibre reinforced)			(carbon fibre filled)			(carbon fibre filled)	
Centrifugal impeller	Polypropylene			ECTFE			ECTFE	
Operating temperature	-5 up to +80 °C			-20 up to +100 °C			-20 up to +100 °C	
Environment temperature	0 up to +40 °C			-20 up to +40 °C			-20 up to +40 °C	
Bearing system	R <sub>1</sub>	X <sub>1</sub>	N <sub>1</sub>	R <sub>2</sub>	X <sub>2</sub>	N <sub>2</sub>	R <sub>2</sub>	N <sub>2</sub>
Guide bearing	HD-carbon	SiC	Rulon®	HD-carbon	SiC	Rulon®	HD-carbon	Rulon®
Shaft	ceramics			SiC			SiC	
Thrust ring	ceramics			SiC			SiC	
O ring	FPM <sup>1)</sup>			FPM <sup>1)2)</sup>			FPM <sup>1)2)</sup>	
Screws	SS			SS			SS	

On request: <sup>1)</sup>EPDM and <sup>2)</sup>FFKM

Technical data		04.04			04.08			06.08			06.10		
Motor selection		N	P	S	N	P	S	N	P	S	N	P	S
Inlet-∅	BSP	G 3/4 IT			G 1 OT			G 1 1/4 OT			G 1 1/4 OT		
Outlet-∅	BSP	G 3/4 OT			G 1 OT			G 1 1/4 OT			G 1 1/4 OT		
Hose connector	mm	25.5			-			-			-		
Inlet and outlet flange	DN	-			25			32			32		
Density max.	kg/dm <sup>3</sup>	1.05	1.35	1.8	1.05	1.35	1.8	1.05	1.35	1.8	1.05	1.35	1.8
Motor power (IEC) 50 Hz	kW	0.18	0.25	0.37	0.25	0.37	0.55	0.37	0.55	0.75	0.55	0.75	1.1
Motor	3-Phase 400 V / 50 Hz, IP 55 (1-Phase 230 V / 50 Hz)												

\*Special voltages on request Rulon® is a registered Trademark of Saint-Gobain. OT = Outer thread IT= Inner thread

# Lutz Horizontal Centrifugal Pumps

TMR: Patented solution, able for dry running

## For almost all liquids

The use of high-quality materials in the housing and bearing ensure pumps of the TMR series have excellent chemical and mechanical properties. In addition to pure liquids, suspensions containing small amounts of solids and high-density liquids can also be pumped.

## Designed for dry running

The patented “magnetic axial thrust self-aligning system” makes it possible to operate all TMR pumps with HD carbon slide bearings (“R” bearing system) under dry running conditions for a limited amount of time with no danger.

## Sturdy design

The housing has reinforcing ribs for pressure bearing. A metallic protection plate (G2 optional) provides additional stability and protects the pump housing from mechanical damage caused by fluctuating system pressures.



## Lower downtimes

Assembly or disassembly of the pump housing does not require special tools, plus the simple design, using few wearing parts and components, all ensure a quick and simple maintenance.

## Suction and discharge connections

Suction and discharge connections, are available with threads (BSP, NPT) or flanges (ISO, ANSI).

### The operating principle of magnetic axial thrust compensation

Introducing an additional magnetic field ensures permanent axial thrust compensation. If dry running occurs due to a drop in pressure, lack of liquid or for other reasons, the impeller assembly is automatically shifted by the additional magnetic field to a neutral position between the front and back axial bearings. In this position there is negligible friction on the axial bearings.

- 1 Pump housing
- 2 Impeller
- 3 Permanent magnet
- 4 **Central disk with additional magnetic field**
- 5 Rear casing
- 6 O ring
- 7 Drive magnet
- 8 Bracket
- 9 Guard plate

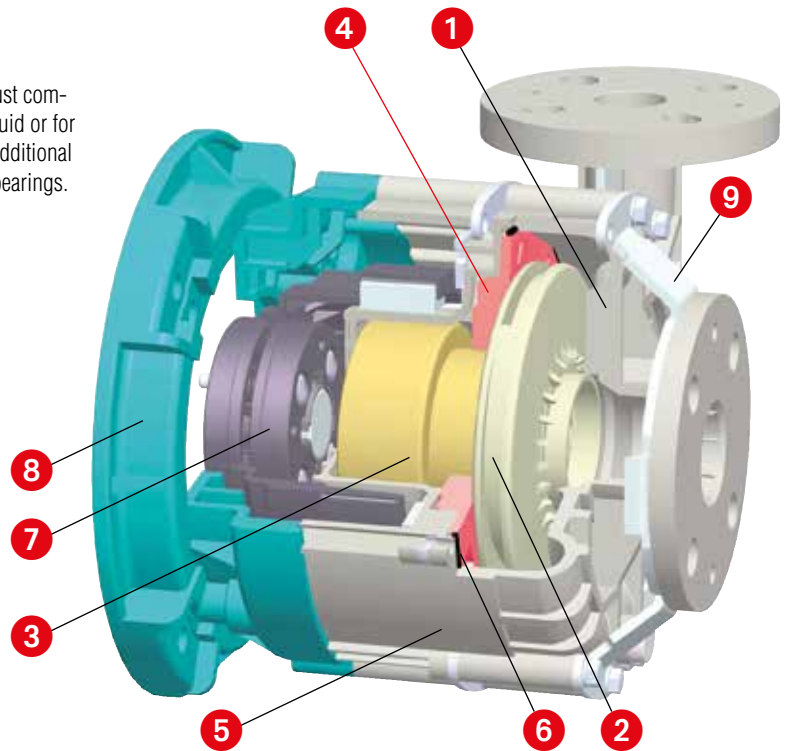

**EU-Patent No. 1152151**  
**US-Patent No. 6,551,075**

### Normal running

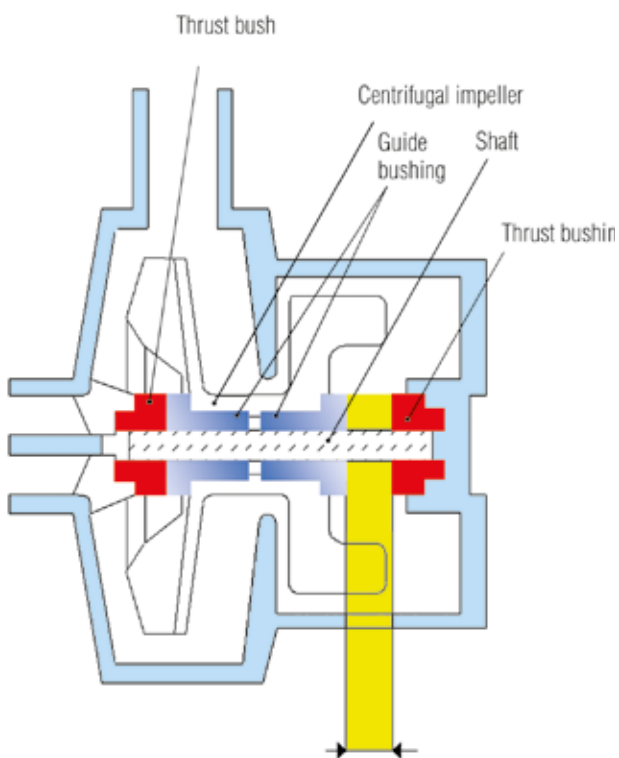

**Generously dimensioned guide bushing for continuous operation**

### Dry running operation

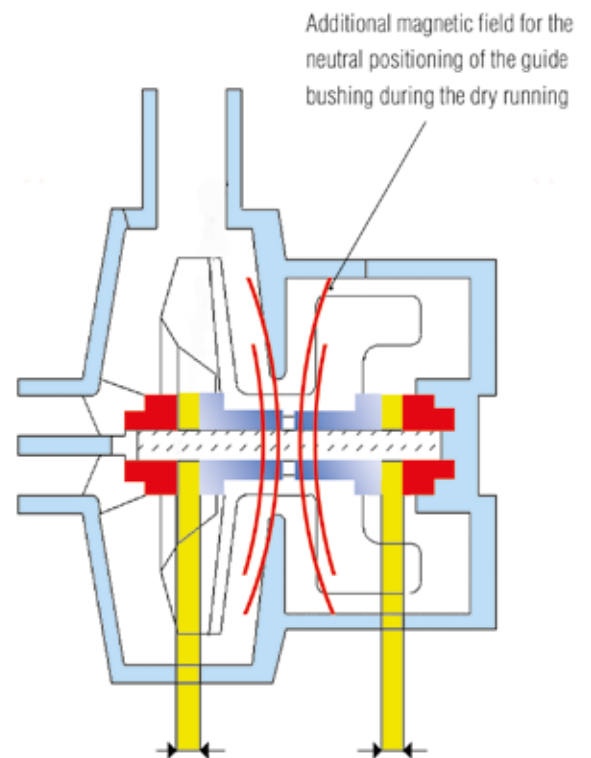

**Contact free operation upon dry running**



# Lutz Horizontal Centrifugal Pumps

TMR G2 Series: Absolutely safe for dry running for medium quantities

✓ **Absolutely safe for dry running**

The "R" version is suitable for dry running by means of a patented magnetic "two axial directions self-aligning system". (Version WR and GF)

✓ **High performance**

TMR range gives up to 30 m³/h and 30 m delivery head, covers densities up to 1.8 kg/dm³ and viscosities up to 150 mPas.

✓ **High system availability**

Due to the special design characteristics, the pumps can even be used under the heaviest conditions.

✓ **Variable connection possibilities**

Various threads and flanges are possible. (BSP, NPT, ISO, ANSI)

✓ **Also suitable for combustible media**

Design GX approved according to ATEX.



**EU-Patent No. 1152151**  
**US-Patent No. 6,551,075**

**Pump construction**

- Patented two axial directions self-aligning system
- **Pump material**  
**WR:** Polypropylene (glass fibre reinforced)  
**GF/GX:** ECTFE (carbon fibre filled)
- **Bearing material**  
HD-carbon, silicon carbide, Rulon®, ceramics
- **Housing seal**  
FPM, EPDM or FFPM
- **Drive magnet**  
Neodymium-Iron-Boron

## Bearing systems TMR G2

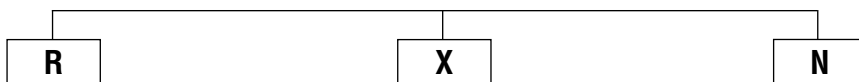

**Designed for dry running**

Designed for dry running through the use of **HD carbon** slide bearings



**Adequate for solids**

Adequate for solids through the use of **silicon carbide** slide bearings



**Corrosion resistant**

Adequate for bromine and chromium compounds through the use of **Rulon®** slide bearings

Rulon® is a registered Trademark of Saint-Gobain.

### Performance curve

Single performance curve in 50 Hz and 60 Hz on request.

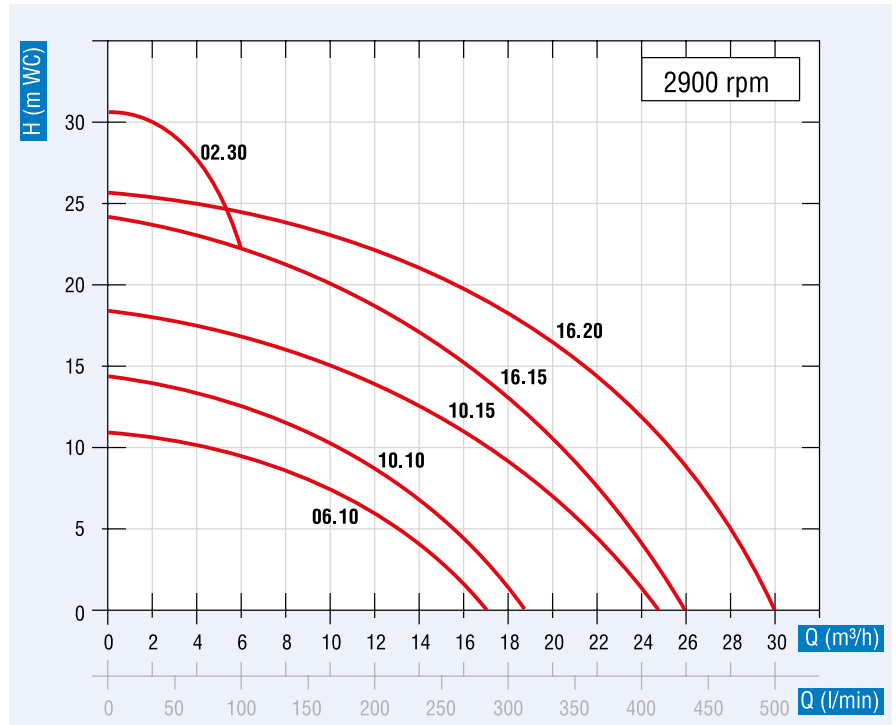

Type	WR			GF			GX	
Category 2 (acc. to ATEX)	no			no			yes	
Volute casing	Polypropylene			ECTFE			ECTFE	
Rear casing	(glass fibre reinforced)			(carbon fibre filled)			(carbon fibre filled)	
Centrifugal impeller	Polypropylene			ECTFE			ECTFE	
Operating temperature	-5 up to +80 °C			-20 up to +100 °C			-20 up to +100 °C	
Environment temperature	0 up to +40 °C			-20 up to +40 °C			-20 up to +40 °C	
Bearing system	R <sub>1</sub>	X <sub>1</sub>	N <sub>1</sub>	R <sub>2</sub>	X <sub>2</sub>	N <sub>2</sub>	R <sub>2</sub>	N <sub>2</sub>
Guide bearing	HD-carbon	SiC	Rulon®	HD-carbon	SiC	Rulon®	HD-carbon	Rulon®
Shaft	ceramics			SiC			SiC	
Thrust ring	ceramics			SiC			SiC	
O-ring	FPM <sup>1)</sup>			FPM <sup>1)2)</sup>			FPM <sup>1)2)</sup>	
Screws	SS			SS			SS	

On request: <sup>1)</sup>EPDM and <sup>2)</sup>FFKM

Technical data		06.10			10.10			10.15			16.15			16.20			02.30		
Motor selection		N	P	S	N	P	S	N	P	S	N	P	S	N	P	S	N	P	S
∅ Inlet	BSP	G 1 1/2 OT			G 1 1/2 OT			G 1 1/2 OT			G 1 1/2 OT			G 1 1/2 OT			G 1 1/2 OT		
∅ Outlet	BSP	G 1 1/4 OT			G 1 1/4 OT			G 1 1/4 OT			G 1 1/4 OT			G 1 1/4 OT			G 1 1/4 OT		
Suction and pressure flange ISO	Suction (mm)	40			40			40			40			40			40		
	Pressure (mm)	32 (40*)			32 (40*)			32 (40*)			32 (40*)			32 (40*)			32 (40*)		
Density max.	kg/dm <sup>3</sup>	1.05	1.35	1.8	1.05	1.35	1.8	1.05	1.35	1.8	1.05	1.35	1.8	1.1	1.35	1.8	1.05	1.35	1.8
Power (IEC) 50 Hz	kW	0.55	0.75	1.1	0.75	1.1	1.5	1.1	1.5	2.2	1.5	2.2	3	2.2	3	–	2.2	3	–
Motor**		3-Phase 400 V / 50 Hz / IP 55 (1-Phase 230 V / 50 Hz < 3 kW)																	

\* On request Rulon® is a registered Trademark of Saint-Gobain. OT = Outer thread IT = Inner thread

\*\* Energy efficiency class IE 3 in accordance with EU regulations 640/2009 and 04/2014

# Lutz Horizontal Centrifugal Pumps

TMR G3 Series: Absolutely safe for dry running for large quantities

✓ **Absolutely safe for dry running**

The "R" version is suitable for dry running by means of a patented magnetic "two axial directions self-aligning system". (Version WR and GF)

✓ **High performance**

TMR range gives up to 48 m³/h and 42 m delivery head, covers densities up to 1.8 kg/dm³ and viscosities up to 150 mPas.

✓ **High system availability**

Due to the special design characteristics, the pumps can even be used under the heaviest conditions.

✓ **Protection plate**

Protects the pump housing against mechanical damage.

✓ **Variable connection possibilities**

Various threads and flanges are possible. (BSP, NPT, ISO, ANSI)

✓ **Also suitable for combustible media**

Design GX approved according to ATEX.



**EU-Patent No. 1152151**  
**US-Patent No. 6,551,075**

**Pump construction**

- Patented two axial directions self-aligning system
- **Pump material**  
**WR:** Polypropylene (glass fibre reinforced)  
**GF/GX:** ECTFE (carbon fibre filled)
- **Bearing material**  
 HD-carbon, silicon carbide, Rulon®, ceramics
- **Housing seal**  
 FPM, EPDM or FFPM
- **Drive magnet**  
 Neodymium-Iron-Boron

## Bearing systems TMR G3

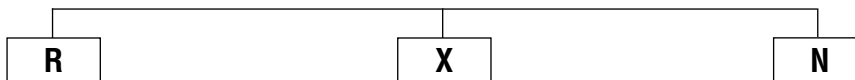

**Designed for dry running**

Designed for dry running through the use of **HD carbon** slide bearings



**Adequate for solids**

Adequate for solids through the use of **silicon carbide** slide bearings





**Corrosion resistant**

Adequate for bromine and chromium compounds through the use of **Rulon®** slide bearings

### Performance curve

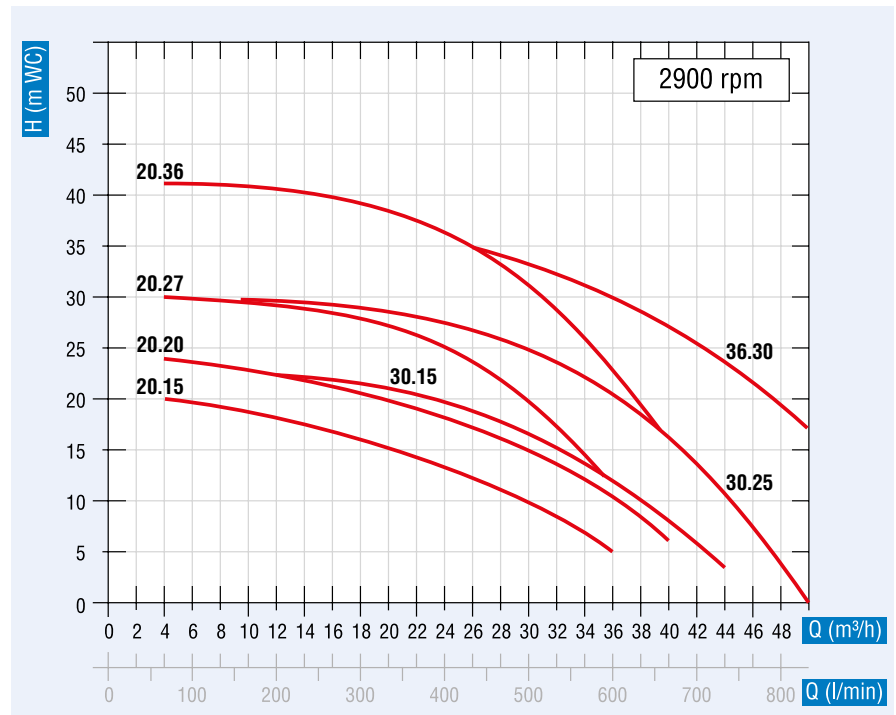
Single performance curve in 50 Hz and 60 Hz on request.



Type	WR			GF			GX 	
Category 2 (acc. to ATEX)	no			no			yes	
Volute casing	Polypropylene			ECTFE			ECTFE	
Rear casing	(glass fibre reinforced)			(carbon fibre filled)			(carbon fibre filled)	
Centrifugal impeller	Polypropylene			ECTFE			ECTFE	
Operating temperature	-5 up to +80 °C			-20 up to +100 °C			-20 up to +100 °C	
Environment temperature	0 up to +40 °C			-20 up to +40 °C			-20 up to +40 °C	
Bearing system	R <sub>1</sub>	X <sub>1</sub>	N <sub>1</sub>	R <sub>2</sub>	X <sub>2</sub>	N <sub>2</sub>	R <sub>2</sub>	N <sub>2</sub>
Guide bearing	HD-carbon	SiC	Rulon®	HD-carbon	SiC	Rulon®	HD-carbon	Rulon®
Shaft	ceramics			SiC			SiC	
Thrust ring	ceramics			SiC			SiC	
O ring	FPM <sup>1)</sup>			FPM <sup>1)2)</sup>			FPM <sup>1)2)</sup>	
Screws	SS			SS			SS	

On request: <sup>1)</sup>EPDM and <sup>2)</sup>FFKM (FFPM)

Technical data		20.15			20.20			20.27			20.36			30.15			30.25			36.30		
Motor selection		N	P	S	N	P	S	N	P	S	N	P	S	N	P	S	N	P	S	N	P	S
∅ Inlet	BSP	G 2 OT			G 2 OT			G 2 OT			G 2 OT			G 2 OT			G 2 OT			G 2 OT		
∅ Outlet	BSP	G 1 1/2 OT			G 1 1/2 OT			G 1 1/2 OT			G 1 1/2 OT			G 1 1/2 OT			G 1 1/2 OT			G 1 1/2 OT		
Suction and pressure flange ISO	Suction (mm)	50			50			50			50			50			50			50		
	Pressure (mm)	40			40			40			40			40			40			40		
Density max.	kg/dm <sup>3</sup>	1.05	1.35	1.8	1.05	1.35	1.8	1.05	1.35	1.8	1.05	1.35	1.8	1.05	1.35	1.8	1.05	1.35	1.8	1.05	1.35	1.8
Power (IEC) 50 Hz	kW	2.2	3	4	3	4	5.5	4	5.5	7.5	5.5	7.5	11	4	5.5	7.5	5.5	7.5	11	7.5	11	–
Motor**		3-Phase 400 V / 50 Hz, IP 55																				

Rulon® is a registered Trademark of Saint-Gobain. OT = Outer thread IT = Inner thread  
 \*\* Energy efficiency class IE 3 in accordance with EU regulations 640/2009 and 04/2014

Twice the **COMPETENCE...**



## Professional Fluid Management

Drum pump sets

Drum and container pumps

Eccentric screw drum pumps

Flow meter systems

Air operated double diaphragm pumps

Vertical and horizontal centrifugal pumps



**Lutz Pumpen GmbH**

P.O. Box 14 62 · D-97864 Wertheim · Phone: (+49 93 42) 8 79-0 · Fax: (+49 93 42) 87 94 04 · E-Mail: [info@lutz-pumpen.de](mailto:info@lutz-pumpen.de)

[www.lutz-pumpen.de](http://www.lutz-pumpen.de)



...simply **UNIQUE**



## A Measured Step Forward



Dosing pumps and accessories  
Chlorinators  
Measuring and control technology

System and process technology  
Chemical centrifugal pumps  
Water disinfection



**Lutz-Jesco GmbH**

Am Bostelberge 19 · D-30900 Wedemark · Phone (+49 51 30) 58 02-0 · Fax (+49 51 30) 58 02 68 · E-Mail: [info@lutz-jesco.com](mailto:info@lutz-jesco.com)

[www.lutz-jesco.de](http://www.lutz-jesco.de)





## **Lutz Pumpen GmbH**

P.O. Box 14 62  
D-97864 Wertheim  
Phone: (0 93 42) 8 79-0  
Fax: (0 93 42) 87 94 04  
E-Mail: [info@lutz-pumpen.de](mailto:info@lutz-pumpen.de)

[www.lutz-pumpen.de](http://www.lutz-pumpen.de)