

## Horizontal Container Pump Lutz B200

# Container Emptying: The Compact Solution

For the optimal transfer of thin-bodied,  
light- or low viscous mediums



**Safety is our Concern**

# Horizontal Container Pump Lutz B200

**This very compact pump is an interesting alternative when containers are stored above each other. Lutz B200 is directly connected to the bottom outlet valve.**

In these cases an access from above is not possible, but the bottom drain of the IBC can be used. For this purpose the new horizontal Lutz B200 is directly connected to the bottom outlet valve. The hydraulic capacity is much more higher compared with a hydrostatic outlet.

In combination with hose and nozzle, this pump allows a controlled filling and also can be operated against a closed valve.

Pressure joint with thread or clamp connection

A union nut enables a quick mounting at the outlet of the container

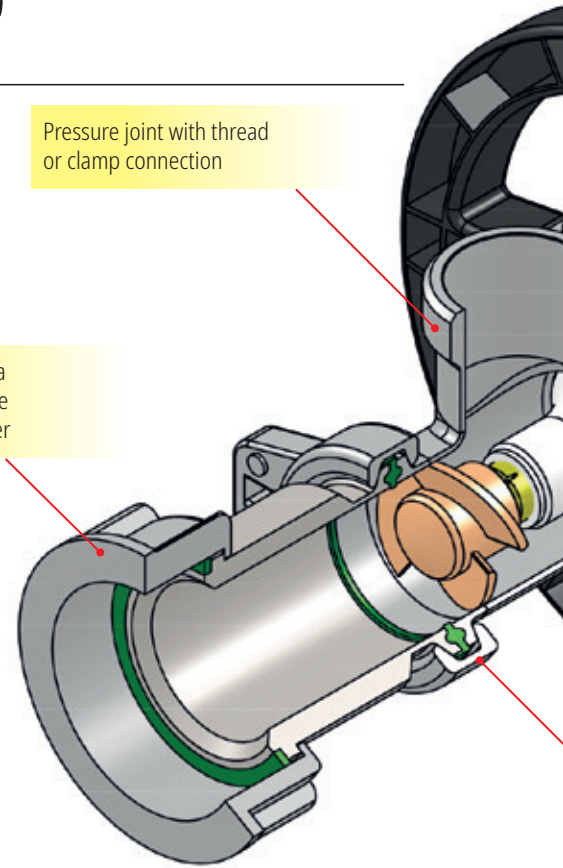

## Product Features:

- » Centrifugal pump with axial impeller in compact design, **small space requirement**
- » Directly connected to the bottom outlet valve of the IBC with standard union nut (S60 x 6)
- » **Variable drive concept** (different universal- and air-driven motors)
- » **Easy disassembly**, two-piece pump with clamp connections acc. to DIN 32676
- » **No suction hose necessary**, thus significantly lower product release when disconnecting
- » **Explosion proof** versions for applications in Ex-areas (zone 1 and 2), including check valve
- » Significantly **better hydraulic capacity** in comparison to hydrostatic outlet
- » Operation against closed valves (e.g. ball valve, nozzle) is possible at any time

## Typical Pumping Mediums:

- » Thin-bodied mineral oil products
- » Emulsions
- » Solvents
- » Aqueous solutions
- » Acids and alkalis
- » Vegetable oils
- » Cleansing- and cosmetic care products, disinfectants





See the video now!

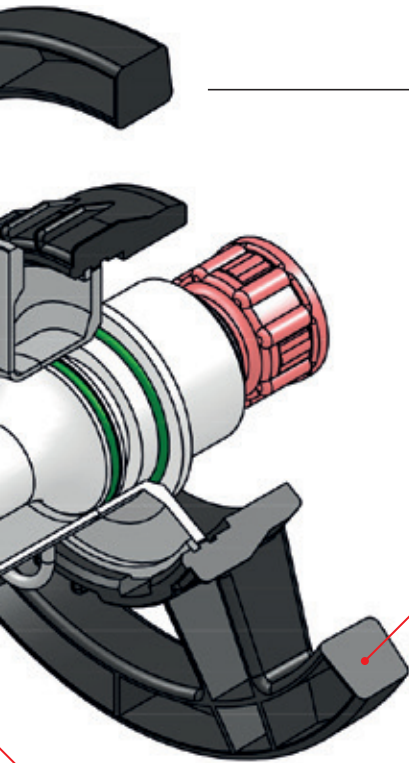

The Lutz hand wheel connects motor and pump and allows a quick disconnection

A clamp connection connects the two-part pump

### Flow Capacities:

Similar to the conventional Lutz drum- and container pumps, this new pump tube can be combined as well with different universal- and air-driven motors<sup>1</sup>, resulting in different flow capacities.

<sup>1</sup>Motors – see general catalogue

### Available Pump Tubes for the Container Pump Lutz B200:

Ref.-No.	Description
0151-400	Pump Tube B200 SS 41-R-MS FPM, OT 1 1/4"
0151-401	Pump Tube B200 PURE SS 41-R-MS FPM, Clamp DN 32
0151-402	Pump Tube B200 PURE SS 41-R-MS EPDM, Clamp DN 32
0151-403	Pump Tube B200 Ex PURE SS 41-R-MS FPM, Clamp DN 32
0151-404	Pump Tube B200 Ex PURE SS 41-R-MS EPDM, Clamp DN 32

### Technical Data:

Flow rate:	max. up to 244 l/min
Delivery head:	max. up to 15 m wc
Viscosity:	max. up to 650 mPas
Density:	max. up to 2,8 kg/dm <sup>3</sup>
Temperature:	max. up to 100 °C
Weight:	approx. 1,5 kg
Materials:	Stainless steel 1.4571, ETFE, PTFE Carbon, Ceramics, FPM or EPDM

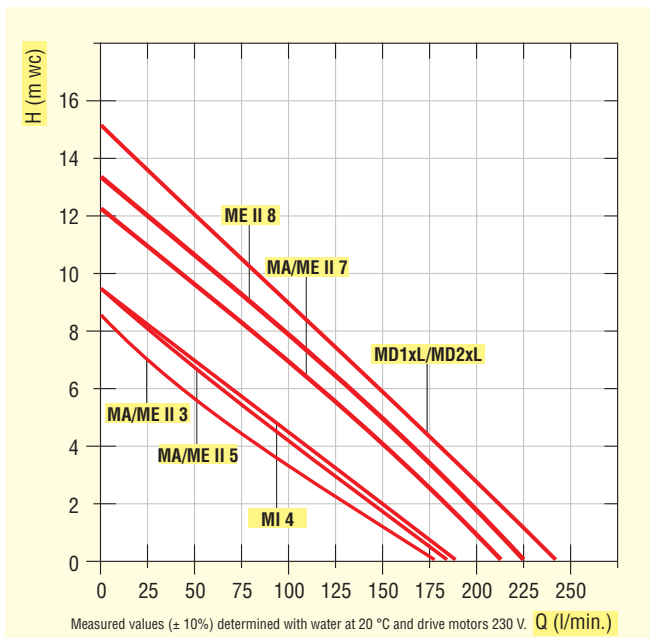

### Available Accessories:

Ref.-No.	Description
0370-104	Adapter fitting Tri-Clamp (1.4404), DN 32 / G 1 1/4 AG
0370-088	Tri-clamp locking clamp (1.4408), DN25/32/40
0314-596	Tri-Clamp seal, DN 32, EPDM
0314-597	Tri-Clamp seal, DN 32, FPM
0208-202	Check valve SS, Clamp DN 32, FPM
0208-203	Check valve SS, Clamp DN 32, EPDM
0208-192	Mounting bracket B200
0208-193	Turnbuckle
0151-416	Stainless steel nut, S60 x 6
	Hoses – see accessories drum pumps
	Valves – see accessories drum pumps



## **Lutz Pumpen GmbH**

Erlenstraße 5-7  
D-97877 Wertheim  
Phone: +49 (0) 93 42 / 8 79-0  
Fax: +49 (0) 93 42 / 87 94 04  
e-mail: [info@lutz-pumpen.de](mailto:info@lutz-pumpen.de)

[www.lutz-pumpen.de](http://www.lutz-pumpen.de)